



TRANSPORTATION CABINET

Frankfort, Kentucky 40622
www.transportation.ky.gov/

Steven L. Beshear
Governor

Michael W. Hancock, P.E.
Secretary

November 14, 2014

CALL NO. 201
CONTRACT ID NO. 141291
ADDENDUM # 3

Subject: Fayette County, 121GR14D091-NHPP & JL04
Letting November 21, 2014

- (1) Revised - Plan Sheets - R2N & R56
- (2) Revised - Material Summary - Pages 243-256 of 360
- (3) Added - Sanitary Sewer - Pages 1-127 of 127

Proposal revisions are available at <http://transportation.ky.gov/Construction-Procurement/>.

Plan revisions are available at <http://www.lynnimaging.com/kytransportation/>.

If you have any questions, please contact us at 502-564-3500.

Sincerely,

A handwritten signature in blue ink that reads "Diana Castle Radcliffe".

Diana Castle Radcliffe
Director
Division of Construction Procurement

DR:ks

Enclosures



An Equal Opportunity Employer M/F/D

COUNTY OF	ITEM NO.	SHEET NO.
FAYETTE	7-113.01	R2N

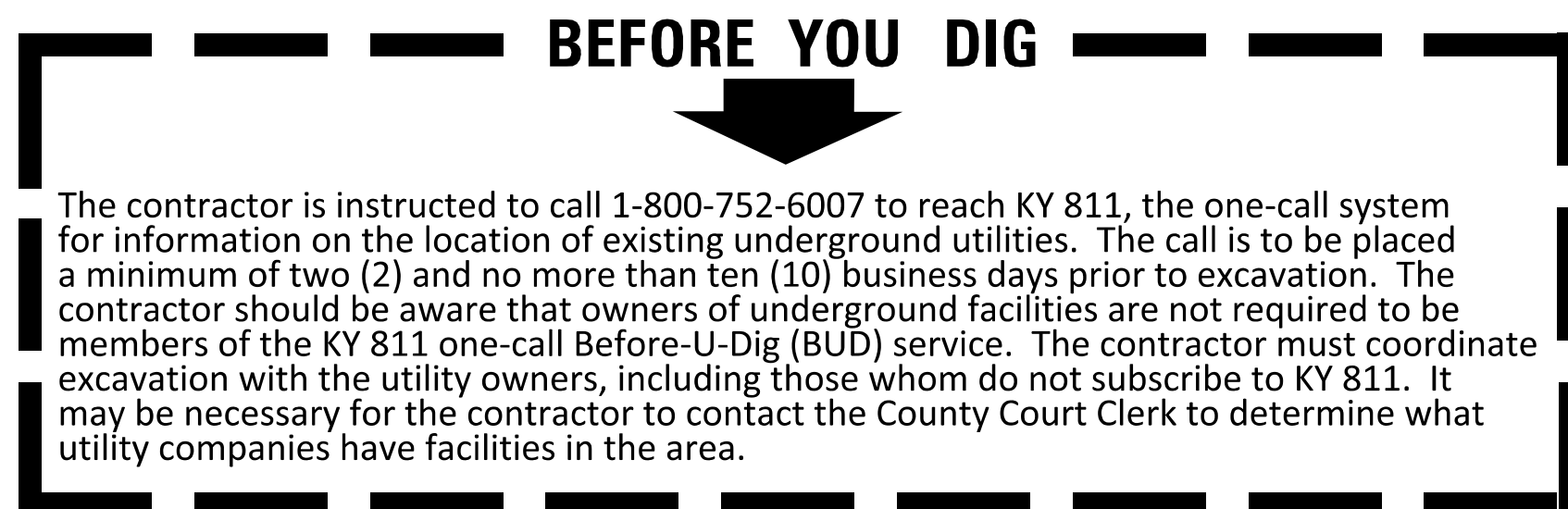

The contractor is instructed to call 1-800-752-6007 to reach KY 811, the one-call system for information on the location of existing underground utilities. The call is to be placed a minimum of two (2) and no more than ten (10) business days prior to excavation. The contractor should be aware that owners of underground facilities are not required to be members of the KY 811 one-call Before-U-Dig (BUD) service. The contractor must coordinate excavation with the utility owners, including those whom do not subscribe to KY 811. It may be necessary for the contractor to contact the County Court Clerk to determine what utility companies have facilities in the area.

SPECIAL NOTES

- FOR PORTABLE CHANGEABLE MESSAGE SIGN
- FOR TURF REINFORCEMENT MAT
- FOR ROCK BLASTING
- FOR EROSION PREVENTION AND SEDIMENT CONTROL
- FOR BORING AND JACKING WITHOUT CARRIER PIPE
- FOR BARCODE LABEL ON PERMANENT SIGNS
- FOR WATER BLASTING STRIPING REMOVAL
- FOR PROTECTION OF RAILROAD INTEREST

UTILITIES

ALL UTILITIES SHOWN ON THE PLANS ARE FOR REFERENCE ONLY. THE CONTRACTOR SHALL HAVE THE UTILITIES FIELD LOCATED PRIOR TO BEGINNING WORK.

PERFORATED PIPE MEDIAN UNDERDRAIN OUTLETS

OPENINGS FOR THE 6-INCH PERFORATED PIPE MEDIAN PAVEMENT UNDERDRAINS SHALL BE CAST INTO EACH MEDIAN BARRIER BOX INLET LOCATED ALONG NEW CIRCLE ROAD AS PART OF THE CASTING OPERATION FOR EITHER PRECAST OR CAST-IN-PLACE DRAINAGE STRUCTURES. THE CASTING OF THE PERFORATED PIPE OPENINGS SHALL BE CONSIDERED INCIDENTAL TO THE UNIT BID PRICE FOR THE RESPECTIVE DRAINAGE STRUCTURE. PERFORATED PIPE UNDERDRAINS SHALL BE CONSTRUCTED SUCH THAT THEY OUTLET TO THE NEAREST SMALL DRAINAGE STRUCTURE DOWNGRADE FROM THE PIPE RUN.

CROSS SECTIONS

THE EXISTING GROUND LINES OF CROSS SECTIONS FOR THIS PROJECT WERE DEVELOPED FROM AERIAL PHOTOGRAPHY AND SUPPLEMENTED WITH LIMITED AMOUNT OF FIELD SURVEYS. THE RDZ LINES SHOWN ON THE CROSS SECTIONS ARE APPROXIMATE AND WERE DEVELOPED FROM A LIMITED AMOUNT OF GEOTECHNICAL INVESTIGATIONS.

SAW CUTTING PAVED SHOULDERS

PRIOR TO REMOVAL OF THE EXISTING PAVED SHOULDERS FOR FULL-DEPTH PAVEMENT WIDENING, THE PAVED SHOULDERS ALONG THE MEDIAN AND/OR THE OUTER SHOULDERS SHALL BE SAW CUT ALONG A NEAT LINE TO DEPTH THAT WILL ENSURE CLEAN BREAKAGE OF PAVED SHOULDER FROM THE EXISTING LANE PAVEMENT THAT IS DESIGNATED TO REMAIN. THE NECESSARY SAW CUT DEPTH WILL BE DETERMINED BY THE ENGINEER BASED ON SAMPLE SAW CUT AND REMOVAL TESTS PERFORMED BY THE CONTRACTOR.

CRASH CUSHION REPLACEMENT ELEMENTS

THE CONTRACTOR SHALL HAVE A COMPLETE REPLACEMENT UNIT AVAILABLE ON THE PROJECT SITE FOR THE DURATION OF THE PROJECT, UNLESS THE SUPPLIER OF THE SPECIFIED IMPACT ATTENUATOR (CRASH CUSHION) CERTIFIES IN WRITING THAT REPLACEMENT UNITS AND/OR PARTS CAN BE DELIVERED TO THE PROJECT SITE WITHIN 24 HOURS AFTER THEY ARE ORDERED.

PETROLEUM LINE

THE CONTRACTOR SHALL NOT DISTURB THE PETROLEUM LINE LOCATED AT STA. 276+78 NEW CIRCLE ROAD. THE CONTRACTOR SHALL ACCURATELY LOCATE THE PETROLEUM LINE IN THE FIELD PRIOR TO THE BEGINNING OF CONSTRUCTION IN THIS AREA. THE CONTRACTOR SHALL CONTACT WES PHELPS WITH MARATHON PIPE LINE AT 606-923-5589 PRIOR TO THE BEGINNING OF WORK.

CLARK MATERIALS

THE CONSTRUCTION OF THE RETAINING WALL RT. STA. 42+70 TO STA. 46+57 OLD FRANKFORT PIKE SHALL NOT INTERFERE WITH THE OPERATIONS OF CLARK MATERIALS. ACCESS FOR SEMI-TRUCKS AROUND THE STORAGE BUILDINGS SHALL BE MAINTAINED AT ALL TIMES BETWEEN THE HOURS OF 6:30AM AND 4:30PM, MONDAY THROUGH FRIDAY.

RETAINING WALLS

SHORING MAY BE REQUIRED TO CONSTRUCT THE PROPOSED RETAINING WALLS ON THIS PROJECT WITHIN THE RIGHT OF WAY. THE SHORING WILL BE INCIDENTAL TO THE RETAINING WALL CONSTRUCTION.

PLACE SIX INCHES OF TOP SOIL ON ALL DISTURBED AREAS AT THE TOP OF ALL RETAINING WALLS.

MATERIAL TRANSFER VEHICLE

A MATERIAL TRANSFER VEHICLE (MTV) SHALL BE REQUIRED FOR ALL PAVING ON THIS JOB IN ACCORDANCE WITH SECTION 403.02.10 OF STANDARD SPECIFICATION, CURRENT EDITION.

NOTICE OF INTENT

THE CONTRACTOR IS REQUIRED TO FILE NOTICE OF INTENT (NOI) TO THE FRANKFORT REGIONAL OFFICE OF THE DIVISION OF AIR QUALITY TEN (10) BUSINESS DAYS (M-F) PRIOR TO THE START OF ANY DEMOLITION OF BRIDGES.

DIVISION OF AIR QUALITY, FRANKFORT REGIONAL OFFICE
200 FAIR OAKS LANE, THIRD FLOOR, FRANKFORT, KY 40601
JARROD.BELL@KY.GOV

TURF REINFORCEMENT MAT

SEE THE PROPOSAL ATTACHMENTS FOR SUPPLEMENTAL SPECIFICATIONS FOR ROLLED EROSION CONTROL PRODUCTS (RECP) SPECIFICATIONS FOR TURF REINFORCEMENT MATTING.

BACKFILLING BORE PITS

ALL BORE AND JACK PITS THAT ARE EXCAVATED ADJACENT TO THE PROPOSED TRAFFIC LANES OR SHOULDER SHALL BE BACKFILLED WITH FLOWABLE FILL. THE COST OF BACKFILLING WITH FLOWABLE FILL SHALL BE INCIDENTAL TO THE UNIT BID PRICE FOR THE ASSOCIATED PIPE.

DEPARTMENT OF THE ARMY PERMIT AND WATER QUALITY CERTIFICATION APPROVALS

A DEPARTMENT OF THE ARMY (DA) PERMIT, WHICH MAY REQUIRE APPROVAL OF A STATE WATER QUALITY CERTIFICATION FROM THE KENTUCKY DIVISION OF WATER, REGULATES THIS PROJECT AT ONE OR MORE LOCATIONS. PERFORM ALL APPLICABLE WORK IN COMPLIANCE WITH THE CONDITIONS STATED IN THE DA PERMIT AND THE APPROVED WATER QUALITY CERTIFICATION. POST A COPY OF THE DA PERMIT AND THE WATER QUALITY CERTIFICATION IN A CONSPICUOUS PLACE AT THE PROJECT SITE. IF A DA PERMIT OR WATER QUALITY CERTIFICATION APPROVAL IS PENDING, DO NOT WORK IN OR DISTURB THE DESIGNATED AREA(S) UNTIL OBTAINING THE APPROPRIATE APPROVAL(S). REFER TO NOTICE(S) CONTAINED IN THE CONTRACT BID PROPOSAL FOR DESIGNATED AREA(S) WHERE WORK IS PROHIBITED BY THE ABSENCE OF APPROVAL.

ASPHALT PAVEMENT RIDE QUALITY

PAVEMENT RIDEABILITY REQUIREMENTS, IN ACCORDANCE WITH SECTION 410 OF THE STANDARD SPECIFICATIONS, SHALL APPLY ON THIS PROJECT. CATEGORY A SHALL APPLY.

EDGE KEY

THIS WORK INCLUDES CUTTING OUT THE EXISTING ASPHALT SURFACE TO A MINIMUM DEPTH AND WIDTH, AS DETAILED ELSEWHERE IN THE PLANS, SO THAT THE NEW SURFACE MAY HEEL INTO THE EXISTING SURFACE. THE CONTRACT UNIT PRICE BID LINEAR FOOT (PER METER) FOR "EDGE KEY" INCLUDES ALL NECESSARY MATERIALS, LABOR AND EQUIPMENT NECESSARY TO PERFORM THE WORK AND DISPOSE OF THE REMOVED ASPHALT MATERIAL.

STANDARD DRAWINGS

STANDARD DRAWINGS ARE NOT ATTACHED TO THESE PLANS. A STANDARD DRAWING BOOK AND THE HEADBRANCH SUPPLEMENTAL BOOK MAY BE OBTAINED FROM THE POLICY SUPPORT BRANCH OF THE DEPARTMENT OF ADMINISTRATIVE SERVICES IN FRANKFORT, KENTUCKY AT 502-564-3670.

N.G.S. (U.S.G.S.) BENCH MARKS

DO NOT DISTURB N.G.S. (U.S.G.S.) BENCH MARKS IN ANY MANNER UNLESS DIRECTED BY THE ENGINEER.

ASPHALT PAVEMENT RIDE QUALITY

PAVEMENT RIDEABILITY REQUIREMENTS, IN ACCORDANCE WITH SECTION 410 OF THE STANDARD SPECIFICATIONS, SHALL APPLY TO THIS PROJECT. CATEGORY A SHALL APPLY.

COMPACTION OF ASPHALT MIXTURES

WILL ACCEPT THE COMPACTION OF ASPHALT MIXTURES FURNISHED FOR DRIVING LANES AND RAMPS AT ONE INCH OR GREATER ON THIS PROJECT BY OPTION A ACCORDING TO SUBSECTIONS 402 AND 403 OF THE CURRENT STANDARD SPECIFICATIONS. USE JOINT CORES AS DESCRIBED IN SUBSECTION 402.03.02 FOR SURFACE MIXTURES ONLY. WILL ACCEPT THE COMPACTION OF ALL OTHER ASPHALT MIXTURES BY OPTION B.

INSPECT AND CLEAN PIPE

THE CONTRACTOR SHALL INSPECT AND CLEAN ALL EXISTING PIPES AS DIRECTED BY THE ENGINEER THAT ARE TO REMAIN OF ALL SEDIMENT AND OTHER DEBRIS. THIS WORK SHALL BE DONE UNDER THE BID ITEM CLEAN ROADWAY DRAINS.

OLD FRANKFORT PIKE LANDFILL

THERE MAY BE SOLID WASTE STILL PRESENT WITHIN THE CURRENT RIGHT OF WAY NEAR OLD FRANKFORT PIKE AND NEW CIRCLE ROAD INTERCHANGE AT APPROXIMATE STA. 298+00 TO STA. 314+00. IF SOLID WASTE IS ENCOUNTERED DURING CONSTRUCTION IN THIS AREA IT IS TO BE DISPOSED OF AS SOLID WASTE AT AN APPROPRIATE FACILITY.

FILE NAME: U:\113\FINAL PLAN SUBMITTAL\FINAL CONTRACT PLANS\CONTRACT PLAN SET\ROADWAY\ROADWAY PLANS\RD020N01.DGN

USER: Joshua.comple DATE PLOTTED: November 14, 2014

E-SHEET NAME:

MicroStation v8.11.7.443

GENERAL NOTES

COUNTY OF	ITEM NO.	SHEET NO.
FAYETTE	7-113.01	R2N

REVISED 11-14-2014

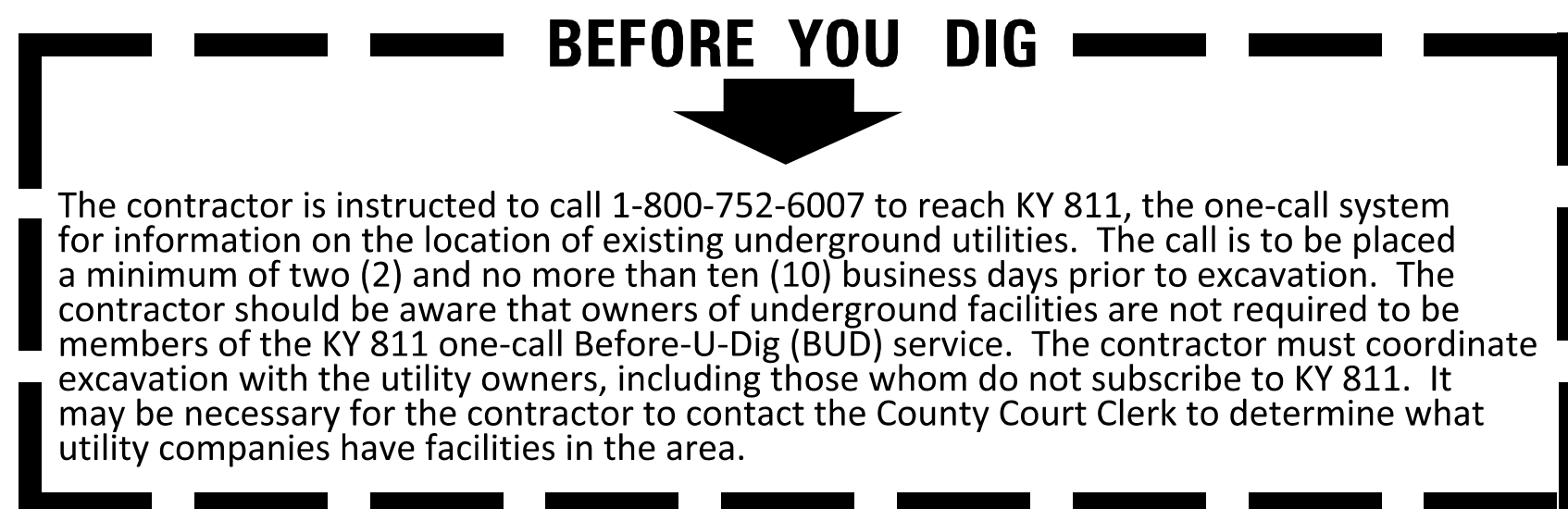

SPECIAL NOTES

- FOR PORTABLE CHANGEABLE MESSAGE SIGN
- FOR TURF REINFORCEMENT MAT
- FOR ROCK BLASTING
- FOR EROSION PREVENTION AND SEDIMENT CONTROL
- FOR BORING AND JACKING WITHOUT CARRIER PIPE
- FOR BARCODE LABEL ON PERMANENT SIGNS
- FOR WATER BLASTING STRIPING REMOVAL
- FOR PROTECTION OF RAILROAD INTEREST

UTILITIES

ALL UTILITIES SHOWN ON THE PLANS ARE FOR REFERENCE ONLY. THE CONTRACTOR SHALL HAVE THE UTILITIES FIELD LOCATED PRIOR TO BEGINNING WORK.

PERFORATED PIPE MEDIAN UNDERDRAIN OUTLETS

OPENINGS FOR THE 6-INCH PERFORATED PIPE MEDIAN PAVEMENT UNDERDRAINS SHALL BE CAST INTO EACH MEDIAN BARRIER BOX INLET LOCATED ALONG NEW CIRCLE ROAD AS PART OF THE CASTING OPERATION FOR EITHER PRECAST OR CAST-IN-PLACE DRAINAGE STRUCTURES. THE CASTING OF THE PERFORATED PIPE OPENINGS SHALL BE CONSIDERED INCIDENTAL TO THE UNIT BID PRICE FOR THE RESPECTIVE DRAINAGE STRUCTURE. PERFORATED PIPE UNDERDRAINS SHALL BE CONSTRUCTED SUCH THAT THEY OUTLET TO THE NEAREST SMALL DRAINAGE STRUCTURE DOWNGRADE FROM THE PIPE RUN.

CROSS SECTIONS

THE EXISTING GROUND LINES OF CROSS SECTIONS FOR THIS PROJECT WERE DEVELOPED FROM AERIAL PHOTOGRAPHY AND SUPPLEMENTED WITH LIMITED AMOUNT OF FIELD SURVEYS. THE RDZ LINES SHOWN ON THE CROSS SECTIONS ARE APPROXIMATE AND WERE DEVELOPED FROM A LIMITED AMOUNT OF GEOTECHNICAL INVESTIGATIONS.

SAW CUTTING PAVED SHOULDERS

PRIOR TO REMOVAL OF THE EXISTING PAVED SHOULDERS FOR FULL-DEPTH PAVEMENT WIDENING, THE PAVED SHOULDERS ALONG THE MEDIAN AND/OR THE OUTER SHOULDERS SHALL BE SAW CUT ALONG A NEAT LINE TO DEPTH THAT WILL ENSURE CLEAN BREAKAGE OF PAVED SHOULDER FROM THE EXISTING LANE PAVEMENT THAT IS DESIGNATED TO REMAIN. THE NECESSARY SAW CUT DEPTH WILL BE DETERMINED BY THE ENGINEER BASED ON SAMPLE SAW CUT AND REMOVAL TESTS PERFORMED BY THE CONTRACTOR.

CRASH CUSHION REPLACEMENT ELEMENTS

THE CONTRACTOR SHALL HAVE A COMPLETE REPLACEMENT UNIT AVAILABLE ON THE PROJECT SITE FOR THE DURATION OF THE PROJECT, UNLESS THE SUPPLIER OF THE SPECIFIED IMPACT ATTENUATOR (CRASH CUSHION) CERTIFIES IN WRITING THAT REPLACEMENT UNITS AND/OR PARTS CAN BE DELIVERED TO THE PROJECT SITE WITHIN 24 HOURS AFTER THEY ARE ORDERED.

PETROLEUM LINE

THE CONTRACTOR SHALL NOT DISTURB THE PETROLEUM LINE LOCATED AT STA. 276+78 NEW CIRCLE ROAD. THE CONTRACTOR SHALL ACCURATELY LOCATE THE PETROLEUM LINE IN THE FIELD PRIOR TO THE BEGINNING OF CONSTRUCTION IN THIS AREA. THE CONTRACTOR SHALL CONTACT WES PHELPS WITH MARATHON PIPE LINE AT 606-923-5589 PRIOR TO THE BEGINNING OF WORK.

CLARK MATERIALS

THE CONSTRUCTION OF THE RETAINING WALL RT. STA. 42+70 TO STA. 46+57 OLD FRANKFORT PIKE SHALL NOT INTERFERE WITH THE OPERATIONS OF CLARK MATERIALS. ACCESS FOR SEMI-TRUCKS AROUND THE STORAGE BUILDINGS SHALL BE MAINTAINED AT ALL TIMES BETWEEN THE HOURS OF 6:30AM AND 4:30PM, MONDAY THROUGH FRIDAY.

RETAINING WALLS

SHORING MAY BE REQUIRED TO CONSTRUCT THE PROPOSED RETAINING WALLS ON THIS PROJECT WITHIN THE RIGHT OF WAY. THE SHORING WILL BE INCIDENTAL TO THE RETAINING WALL CONSTRUCTION.

PLACE SIX INCHES OF TOP SOIL ON ALL DISTURBED AREAS AT THE TOP OF ALL RETAINING WALLS.

MATERIAL TRANSFER VEHICLE

A MATERIAL TRANSFER VEHICLE (MTV) SHALL BE REQUIRED FOR ALL PAVING ON THIS JOB IN ACCORDANCE WITH SECTION 403.02.10 OF STANDARD SPECIFICATION, CURRENT EDITION.

NOTICE OF INTENT

THE CONTRACTOR IS REQUIRED TO FILE NOTICE OF INTENT (NOI) TO THE FRANKFORT REGIONAL OFFICE OF THE DIVISION OF AIR QUALITY TEN (10) BUSINESS DAYS (M-F) PRIOR TO THE START OF ANY DEMOLITION OF BRIDGES.

DIVISION OF AIR QUALITY, FRANKFORT REGIONAL OFFICE
200 FAIR OAKS LANE, THIRD FLOOR, FRANKFORT, KY 40601
JARROD.BELL@KY.GOV

TURF REINFORCEMENT MAT

SEE THE PROPOSAL ATTACHMENTS FOR SUPPLEMENTAL SPECIFICATIONS FOR ROLLED EROSION CONTROL PRODUCTS (RECP) SPECIFICATIONS FOR TURF REINFORCEMENT MATTING.

BACKFILLING BORE PITS

ALL BORE AND JACK PITS THAT ARE EXCAVATED ADJACENT TO THE PROPOSED TRAFFIC LANES OR SHOULDER SHALL BE BACKFILLED WITH FLOWABLE FILL. THE COST OF BACKFILLING WITH FLOWABLE FILL SHALL BE INCIDENTAL TO THE UNIT BID PRICE FOR THE ASSOCIATED PIPE.

DEPARTMENT OF THE ARMY PERMIT AND WATER QUALITY CERTIFICATION APPROVALS

A DEPARTMENT OF THE ARMY (DA) PERMIT, WHICH MAY REQUIRE APPROVAL OF A STATE WATER QUALITY CERTIFICATION FROM THE KENTUCKY DIVISION OF WATER, REGULATES THIS PROJECT AT ONE OR MORE LOCATIONS. PERFORM ALL APPLICABLE WORK IN COMPLIANCE WITH THE CONDITIONS STATED IN THE DA PERMIT AND THE APPROVED WATER QUALITY CERTIFICATION. POST A COPY OF THE DA PERMIT AND THE WATER QUALITY CERTIFICATION IN A CONSPICUOUS PLACE AT THE PROJECT SITE. IF A DA PERMIT OR WATER QUALITY CERTIFICATION APPROVAL IS PENDING, DO NOT WORK IN OR DISTURB THE DESIGNATED AREA(S) UNTIL OBTAINING THE APPROPRIATE APPROVAL(S). REFER TO NOTICE(S) CONTAINED IN THE CONTRACT BID PROPOSAL FOR DESIGNATED AREA(S) WHERE WORK IS PROHIBITED BY THE ABSENCE OF APPROVAL.

ASPHALT PAVEMENT RIDE QUALITY

PAVEMENT RIDEABILITY REQUIREMENTS, IN ACCORDANCE WITH SECTION 410 OF THE STANDARD SPECIFICATIONS, SHALL APPLY ON THIS PROJECT. CATEGORY A SHALL APPLY.

EDGE KEY

THIS WORK INCLUDES CUTTING OUT THE EXISTING ASPHALT SURFACE TO A MINIMUM DEPTH AND WIDTH, AS DETAILED ELSEWHERE IN THE PLANS, SO THAT THE NEW SURFACE MAY HEEL INTO THE EXISTING SURFACE. THE CONTRACT UNIT PRICE BID LINEAR FOOT (PER METER) FOR "EDGE KEY" INCLUDES ALL NECESSARY MATERIALS, LABOR AND EQUIPMENT NECESSARY TO PERFORM THE WORK AND DISPOSE OF THE REMOVED ASPHALT MATERIAL.

STANDARD DRAWINGS

STANDARD DRAWINGS ARE NOT ATTACHED TO THESE PLANS. A STANDARD DRAWING BOOK AND THE HEADWALL SUPPLEMENTAL BOOK MAY BE OBTAINED FROM THE POLICY SUPPORT BRANCH OF THE DEPARTMENT OF ADMINISTRATIVE SERVICES IN FRANKFORT, KENTUCKY AT 502-564-3670.

N.G.S. (U.S.G.S.) BENCH MARKS

DO NOT DISTURB N.G.S. (U.S.G.S.) BENCH MARKS IN ANY MANNER UNLESS DIRECTED BY THE ENGINEER.

ASPHALT PAVEMENT RIDE QUALITY

PAVEMENT RIDEABILITY REQUIREMENTS, IN ACCORDANCE WITH SECTION 410 OF THE STANDARD SPECIFICATIONS, SHALL APPLY TO THIS PROJECT. CATEGORY A SHALL APPLY.

COMPACTION OF ASPHALT MIXTURES

WILL ACCEPT THE COMPACTION OF ASPHALT MIXTURES FURNISHED FOR DRIVING LANES AND RAMPS AT ONE INCH OR GREATER ON THIS PROJECT BY OPTION A ACCORDING TO SUBSECTIONS 402 AND 403 OF THE CURRENT STANDARD SPECIFICATIONS. USE JOINT CORES AS DESCRIBED IN SUBSECTION 402.03.02 FOR SURFACE MIXTURES ONLY. WILL ACCEPT THE COMPACTION OF ALL OTHER ASPHALT MIXTURES BY OPTION B.

INSPECT AND CLEAN PIPE

THE CONTRACTOR SHALL INSPECT AND CLEAN ALL EXISTING PIPES AS DIRECTED BY THE ENGINEER THAT ARE TO REMAIN OF ALL SEDIMENT AND OTHER DEBRIS. THIS WORK SHALL BE DONE UNDER THE BID ITEM CLEAN ROADWAY DRAINS.

OLD FRANKFORT PIKE LANDFILL

THERE MAY BE SOLID WASTE STILL PRESENT WITHIN THE CURRENT RIGHT OF WAY NEAR OLD FRANKFORT PIKE AND NEW CIRCLE ROAD INTERCHANGE AT APPROXIMATE STA. 298+00 TO STA. 314+00. IF SOLID WASTE IS ENCOUNTERED DURING CONSTRUCTION IN THIS AREA IT IS TO BE DISPOSED OF AS SOLID WASTE AT AN APPROPRIATE FACILITY.

FILE NAME: U:\113\FINAL PLAN SUBMITTAL\FINAL CONTRACT PLANS\CONTRACT PLAN SET\ROADWAY\ROADWAY PLANS\ROAD02ONGN.DGN

USER: Joshua.comple DATE PLOTTED: November 14, 2014

E-SHEET NAME:

MicroStation v8.11.7.443

GENERAL NOTES

COUNTY OF	ITEM NO.	SHEET NO.
FAYETTE	7-113.01	R56

MAINTENANCE OF TRAFFIC NOTES

GENERAL NOTES

ALL TRAFFIC CONTROL DEVICES SHALL COMPLY WITH THE CURRENT KYTC STANDARD DRAWINGS AND THE CURRENT MANUAL ON UNIFORM TRAFFIC CONTROL DEVICES (MUTCD).

OTHER MAINTENANCE OF TRAFFIC PROPOSALS WILL BE CONSIDERED IN ACCORDANCE WITH THE STANDARD SPECIFICATIONS; HOWEVER, ALTERNATE MAINTENANCE OF TRAFFIC SCHEMES WILL NOT BE SUBJECT TO VALUE ENGINEERING UNDER SECTION III.

IF THE CONTRACTOR DECIDES TO DEVIATE FROM THE TRAFFIC CONTROL SCHEME AND CONSTRUCTION SCHEDULE OUTLINED IN THESE PLANS OR PROPOSAL, AN ALTERNATE PLAN SHALL BE SUBMITTED IN WRITING TO THE PROJECT ENGINEER. THE ALTERNATE PLAN MAY BE USED ONLY IF APPROVED IN WRITING BY THE KENTUCKY DIVISION OF DESIGN, TRAFFIC, AND CONSTRUCTION.

THE REQUIREMENTS FOR ALTERNATE MAINTENANCE OF TRAFFIC SCHEMES ON NEW CIRCLE ROAD SHALL BE AT LEAST 11 FOOT LANES FOR THRU TRAFFIC. TWO LANES PER DIRECTION SHALL BE OPEN TO TRAFFIC AT ALL TIMES, UNLESS OTHERWISE SPECIFIED IN THE MAINTENANCE OF TRAFFIC PLANS.

THE CONTRACTOR SHALL SUBMIT IN WRITING, PLANS FOR APPROVAL BY THE DEPARTMENT BEFORE STOPPING TRAFFIC.

NORMAL CONSIDERATION SHOULD BE GIVEN TO PROPERTY OWNERS FOR THEIR ACCESS.

REPAIR AND/OR UPGRADE PAVEMENT ALONG AND ACROSS EXISTING ROADS WHERE CONSTRUCTION TRAFFIC CROSSES. ACCESS TO ALL PUBLIC ROADS IS TO BE MAINTAINED EXCEPT AS INDICATED IN THE MAINTENANCE OF TRAFFIC NOTES.

CONSTRUCT EROSION CONTROLS AT POINTS WHERE RUNOFF LEAVES THE PROJECT SITE. BEGIN EARTHWORK, UTILIZING TEMPORARY DIVERSION DITCHES TO DIRECT RUNOFF TO EROSION CONTROLS.

THE CONTRACTOR MUST NOTIFY THE PROJECT ENGINEER WITHIN THE FOLLOWING TIME FRAMES OF PENDING CHANGES IN THEIR WORK SCHEDULE WHICH WILL AFFECT TRAFFIC PATTERNS:

- 1) AT LEAST FOURTEEN (14) DAYS PRIOR TO BEGINNING CONSTRUCTION PHASES
- 2) AT LEAST FIVE (5) DAYS PRIOR TO A LANE OR RAMP CLOSURE
- 3) IF A DECISION IS MADE NOT TO CLOSE A LANE OR RAMP, NOTICE MUST BE GIVEN TO THE PROJECT ENGINEER 5 DAYS PRIOR TO THE PROPOSED CLOSURE.

EXCEPT FOR THE ROADWAY AND TRAFFIC CONTROL BID ITEMS LISTED, ALL ITEMS OF WORK NECESSARY TO MAINTAIN AND CONTROL TRAFFIC WILL BE PAID FOR AT THE LUMP SUM BID PRICE OF "MAINTAIN & CONTROL TRAFFIC", AS SET FORTH IN THE CURRENT STANDARD SPECIFICATIONS FOR ROAD AND BRIDGE CONSTRUCTION, UNLESS OTHERWISE PROVIDED FOR IN THESE NOTES.

SPECIAL NOTES

AT ALL TIMES THE CONTRACTOR SHALL WORK IN THE DESIGNATED WORK AREAS. THE CONTRACTOR SHALL NOT PERFORM EXCAVATIONS OR RUN EQUIPMENT OUTSIDE THE ROADWAY DURING THE MEDIAN CONSTRUCTION STAGE UNLESS SO DESIGNATED IN THE PLANS. DURING TIMES WHEN TRAFFIC IS LIMITED TO ONE LANE IN ANY DIRECTION (I.E. GRINDING/STRIPING FOR PHASING TRANSITION, PLACING TEMPORARY CONCRETE BARRIER, ETC) WORK SHALL ONLY BE PERFORMED DURING LOW VOLUME TRAFFIC HOURS.

THE CONTRACTOR'S VEHICLES SHALL ALWAYS MOVE WITH, AND NOT AGAINST, THE FLOW OF TRAFFIC. VEHICLES SHALL ENTER AND LEAVE WORK AREAS IN A MANNER WHICH WILL NOT INTERFERE WITH NORMAL TRAFFIC. VEHICLES SHALL NOT PARK OR STOP EXCEPT WITHIN WORK AREAS DESIGNATED BY THE PROJECT ENGINEER.

THE CONTRACTOR WILL NOT BE ALLOWED TO HAUL EQUIPMENT OR DRIVE ACROSS THE MEDIAN FROM ONE SIDE OF NEW CIRCLE ROAD TO THE OTHER UNLESS APPROPRIATE BARRIER WALL GATES HAVE BEEN INSTALLED. ALL OTHER EQUIPMENT MOVEMENTS FROM ONE SIDE OF NEW CIRCLE ROAD TO THE OTHER SHALL UTILIZE THE NEAREST INTERCHANGE. HAULING EQUIPMENT THAT USES NEW CIRCLE ROAD SHALL BE RESTRICTED TO LICENSED VEHICLES ONLY. VEHICLES SHALL NOT STOP OR PARK IN AREAS NOT DESIGNATED BY THE PROJECT ENGINEER. ANY SHOULDER USED FOR A DECELERATION OR ACCELERATION LANE SHALL BE WIDENED AND PAVED TO ADEQUATELY SUPPORT HEAVY TRUCK TRAFFIC. ALL EXPENSES INCURRED TO CONSTRUCT BARRIER WALL GATES AND REMOVAL THERE OF SHALL BE BORNE BY THE CONTRACTOR AND BE INCIDENTAL TO THE CONTRACT. PAVEMENT NEEDED TO CONSTRUCT BARRIER WALL GATES WILL BE MEASURED FOR PAYMENT.

THE CONTRACTOR SHALL NOTIFY FAYETTE COUNTY 911 SERVICE TWO WEEKS PRIOR TO ROAD CLOSURES.

WHEN SETTING BEAMS, REMOVING OR CONSTRUCTING OVERHEAD SIGN SUPPORTS, AND CHANGING FROM ONE TRAFFIC PATTERN TO ANOTHER, TRAFFIC MAY BE HALTED AT THE NEAREST INTERCHANGE FOR A PERIOD NOT TO EXCEED 30 MINUTES. ROAD CLOSURES SHALL BE ALLOWED ONLY DURING THE HOURS OF MINIMUM TRAFFIC VOLUMES AS DESCRIBED IN THESE TRAFFIC CONTROL NOTES.

LAW ENFORCEMENT OFFICERS (LEO'S)

POLICE SUPPORT SHALL BE A UNIT CONSISTING OF AN OFF-DUTY POLICEMAN FROM ANY POLICE FORCE AGENCY HAVING LAWFUL JURISDICTION AND A POLICE CAR EQUIPPED WITH EXTERNALLY MOUNTED BLUE LIGHTS. IT IS ANTICIPATED THAT APPROXIMATELY TWO (2) OFFICERS WILL BE REQUIRED FOR EACH CLOSURE SET UP. THE OFFICER(S) WILL BE PLACED AT THE DISCRETION OF THE PROJECT ENGINEER.

HOURS OF LOW TRAFFIC VOLUMES

IN THESE NOTES AND FOLLOWING SEQUENCE OF CONSTRUCTION, THE PHRASE "HOURS OF LOW TRAFFIC VOLUMES" IS USED TO SPECIFY A PERIOD OF TIME IN WHICH A LANE CLOSURE MAY BE INSTALLED FOR CONSTRUCTION OPERATIONS ADJACENT TO A TRAVELED WAY. LISTED BELOW ARE THE HOURS OF LOW TRAFFIC VOLUMES.

SOUTHBOUND	NORTHBOUND
MON 7:00 PM - TUE 7:00 AM	MON 7:00 PM - TUE 7:00 AM
TUE 7:00 PM - WED 7:00 AM	TUE 7:00 PM - WED 7:00 AM
WED 7:00 PM - THU 7:00 AM	WED 7:00 PM - THU 7:00 AM
THU 7:00 PM - FRI 7:00 AM	THU 7:00 PM - FRI 7:00 AM
FRI 8:00 PM - SAT 7:00 AM	FRI 8:00 PM - SAT 7:00 AM
SAT 7:00 PM - SUN 7:00 AM	SAT 7:00 PM - SUN 7:00 AM
SUN 7:00 PM - MON 7:00 AM	SUN 7:00 PM - MON 7:00 AM

PRIOR TO THE CONTRACTOR PERFORMING ANY CONSTRUCTION SEQUENCE, HE MUST APPLY IN WRITING TO THE PROJECT ENGINEER FOR APPROVAL OF THE PERIOD OF TIME SELECTED. THE PROJECT ENGINEER, AT HIS DISCRETION, CAN CANCEL OR SHORTEN ANY PERIOD OF TIME BEFORE AND DURING A CONSTRUCTION SEQUENCE. IF THE PROJECT ENGINEER SHORTENS A PERIOD OF TIME BEFORE AND DURING A CONSTRUCTION SEQUENCE, THE CONTRACTOR SHALL REMOVE ALL EQUIPMENT AND INSTALL PROPER TRAFFIC CONTROL DEVICES.

HOURS OF MINIMUM TRAFFIC VOLUMES

IN THESE NOTES AND FOLLOWING SEQUENCE OF CONSTRUCTION, THE PHRASE "HOURS OF MINIMUM TRAFFIC VOLUMES" IS USED TO SPECIFY A TIME FRAME IN WHICH A ROADWAY CAN BE COMPLETELY CLOSED BETWEEN TWO (2) ADJACENT INTERCHANGES IN ORDER TO PERFORM A PARTICULAR CONSTRUCTION SEQUENCE. LISTED BELOW ARE PERIODS OF TIME EACH WEEK THAT ARE CONSIDERED "HOURS OF MINIMUM TRAFFIC VOLUMES".

SOUTHBOUND	NORTHBOUND
MON 10:00 PM - TUE 5:00 AM	MON 10:00 PM - TUE 5:00 AM
TUE 10:00 PM - WED 5:00 AM	TUE 10:00 PM - WED 5:00 AM
WED 10:00 PM - THU 5:00 AM	WED 10:00 PM - THU 5:00 AM
THU 10:00 PM - FRI 5:00 AM	THU 10:00 PM - FRI 5:00 AM
FRI MIDNIGHT - SAT 5:00 AM	FRI MIDNIGHT - SAT 5:00 AM
SAT MIDNIGHT - SUN 5:00 AM	SAT MIDNIGHT - SUN 5:00 AM
SUN MIDNIGHT - MON 5:00 AM	SUN MIDNIGHT - MON 5:00 AM

THE TIME A CONTRACTOR CAN COMPLETELY CLOSE DOWN THE ROADWAY SHALL NOT EXCEED 30 MINUTES. THESE INTERRUPTIONS TO TRAFFIC SHALL NOT OCCUR UNLESS TRAFFIC HAS BEEN RESTORED IN THE OPINION OF THE PROJECT ENGINEER FROM A PRIOR CLOSURE. BLASTING OPERATIONS WILL NOT BE ALLOWED FOR THE TIMES LISTED ABOVE.

OLD FRANKFORT PIKE AND INTERCHANGE RAMP CLOSURES

UNLESS APPROVED DURING THE LOW TRAFFIC AND MINIMUM TRAFFIC HOURS LISTED, TRAFFIC SHALL BE MAINTAINED ON OLD FRANKFORT PIKE AND INTERCHANGE RAMP AT ALL TIMES WITH THE FOLLOWING EXCEPTION. THE CONTRACTOR WILL BE ALLOCATED ONE WEEKEND FOR CLOSURE OF RAMP D, E, F, AND OLD FRANKFORT PIKE AND ONE WEEKEND FOR CLOSURE OF RAMP A, B, C, AND OLD FRANKFORT PIKE (WHILE MAINTAINING ACCESS TO DUNCAN MACHINERY DRIVE) WITH SAID WEEKEND BEGINNING AT 7:00 PM FRIDAY AND ENDING AT 6:00 AM MONDAY. ANY CLOSURE IN PLACE BEYOND 6:00 AM MONDAY WILL BE ASSESSED LIQUIDATED DAMAGES AT THE RATES LISTED UNDER LIQUIDATED DAMAGES AND DISINCENTIVES.

HOLIDAYS AND SPECIAL EVENTS

LISTED BELOW ARE DATES AND TIMES FOR HOLIDAYS AND SPECIAL EVENTS WHEN ROAD CLOSURES, LANE CLOSURES AND BLASTING WILL NOT BE ALLOWED.

2014	
THANKSGIVING	6:00 AM NOVEMBER 26 TO 6:00 AM DECEMBER 1
CHRISTMAS	6:00 PM DECEMBER 23 TO 6:00 AM DECEMBER 26
NEW YEARS	6:00 PM DECEMBER 31 TO 6:00 AM JANUARY 3

2015	
KEA (SPRING BREAK)	TO BE DETERMINED BY THE DEPARTMENT
EASTER	6:00 AM APRIL 3 TO 6:00 AM APRIL 6
MEMORIAL DAY	6:00 AM MAY 21 TO 6:00 AM MAY 26
JULY 4TH	6:00 AM JULY 1 TO 6:00 AM JULY 6
LABOR DAY	6:00 AM SEPTEMBER 4 TO 6:00 AM SEPTEMBER 8
THANKSGIVING	6:00 AM NOVEMBER 25 TO 6:00 AM NOVEMBER 30
CHRISTMAS	6:00 PM DECEMBER 23 TO 6:00 AM DECEMBER 27
NEW YEARS	6:00 PM DECEMBER 30 TO 6:00 AM JANUARY 3

2016	
KEA (SPRING BREAK)	TO BE DETERMINED BY THE DEPARTMENT
EASTER	6:00 AM MARCH 25 TO 6:00 AM MARCH 28
MEMORIAL DAY	6:00 AM MAY 27 TO 6:00 AM MAY 31
JULY 4TH	6:00 AM JULY 1 TO 6:00 AM JULY 5
LABOR DAY	6:00 AM SEPTEMBER 2 TO 6:00 AM SEPTEMBER 6

FUTURE HOLIDAY DATES SHALL BE DETERMINED BY THE DEPARTMENT IF NECESSARY, COMPARABLE TO ABOVE DATES. THE ABOVE DATES ARE SUBJECT TO CHANGE IF THE DEPARTMENT DEEMS NECESSARY.

SPEED LIMIT

THE SPEED LIMIT ON NEW CIRCLE ROAD WILL BE REDUCED TO 45 MPH IN THE WORK ZONE. REDUCED SPEED AHEAD SIGNS (R2-A) AND 45 MPH SIGNS (R2-I) SHALL BE INSTALLED BOTH NORTHBOUND AND SOUTHBOUND. PAYMENT FOR THESE SIGNS SHALL BE IN THE BID ITEM SIGNS - CODE 2562.

THE SPEED LIMIT ON ALL OTHER ROADWAYS WILL BE REDUCED AS NOTED IN THE FOLLOWING PLANS. REDUCED SPEED AHEAD SIGNS (R2-A) AND SPEED LIMIT MPH SIGNS (R2-I) SHALL BE INSTALLED IN BOTH TRAVEL DIRECTIONS. PAYMENT FOR THESE SIGNS SHALL BE IN THE BID ITEM SIGNS - CODE 2562.

BLASTING OPERATIONS

DURING BLASTING OPERATIONS, TRAFFIC IN BOTH DIRECTIONS MAY BE HALTED A MAXIMUM OF 15 MINUTES PER HOUR TO ALLOW THE EXECUTION OF THE "SHOT" AND TO ALLOW FOR REMOVAL OF ROCK FRAGMENTS AND DEBRIS. WHEN USING EXPLOSIVE CHARGES OF ANY KIND FOR THE PURPOSE OF EXCAVATING, THE CONTRACTOR SHALL HALT ALL TRAFFIC A SAFE DISTANCE ON EITHER SIDE OF THE IMPENDING EXPLOSION. THE CONTRACTOR SHALL IMMEDIATELY INSPECT THE PAVEMENTS FOR ANY DEBRIS THAT MAY BE A HAZARD TO TRAFFIC BEFORE ALLOWING TRAFFIC TO PROCEED ON THE AFFECTED SECTION. WHEN BLASTING, THE CONTRACTOR SHALL HALT TRAFFIC, BLAST, CLEAN THE EXISTING PAVEMENTS AND RETURN TRAFFIC TO NORMAL OPERATION IN THE LEAST AMOUNT OF TIME AS POSSIBLE.

LISTED BELOW ARE THE PERIODS OF TIME FOR EACH DAY OF THE WEEK TRAFFIC HALTS FOR BLASTING WILL BE ALLOWED:

MONDAY	9:00 AM TO 2:00 PM
TUESDAY	9:00 AM TO 2:00 PM
WEDNESDAY	9:00 AM TO 2:00 PM
THURSDAY	9:00 AM TO 2:00 PM
FRIDAY	9:00 AM TO 2:00 PM

LIQUIDATED DAMAGES AND DISINCENTIVES

THE FOLLOWING DAMAGES SHALL BE ASSESSED IF ROAD CLOSURES ARE KEPT FOR LONGER THAN 15 MINUTES DURING BLASTING OPERATIONS:

15 TO 30 MINUTES	\$10,000.00
30 TO 45 MINUTES	\$20,000.00
45 TO 60 MINUTES	\$40,000.00

ALL ROAD CLOSURES LEFT IN PLACE FOR MORE THAN 60 MINUTES WILL BE ASSESSED DAMAGES OF \$40,000.00 PER HOUR OR FRACTION THEREOF. DAMAGES FOR ANY FRACTION OF AN HOUR WILL BE CHARGED AT THE FULL \$40,000.00 HOURLY RATE. INTERRUPTIONS TO TRAFFIC SHALL NOT OCCUR MORE THAN ONCE IN A PERIOD OF PERMITTED ROAD CLOSURE UNLESS NORMAL TRAFFIC FLOW HAS BEEN RESTORED AND THE PROJECT ENGINEER APPROVES ANOTHER ROAD CLOSURE.

THE CONTRACTOR SHALL SUBMIT IN WRITING PLANS FOR STOPPING TRAFFIC WHICH WILL BE REVIEWED BY THE DEPARTMENT OF HIGHWAYS.

DISINCENTIVES OF \$1,300.00 PER LANE CLOSURE PER HOUR WILL BE CHARGED EACH HOUR OR FRACTION OF AN HOUR THAT TWO LANES IN EACH DIRECTION OF NEW CIRCLE ROAD ARE NOT OPEN EXCEPT FOR PERMITTED HOURS DURING HOURS OF LOW TRAFFIC VOLUME. THE \$1,300.00 DISINCENTIVE SHALL ALSO APPLY TO ANY SINGLE LANE OF TRAFFIC NOT SPECIFICALLY PERMITTED IN THE TRAFFIC CONTROL PLAN. LANE CLOSURES IN PLACE FOR MORE THAN ONE HOUR IN EXCESS OF PERMITTED HOURS WILL BE ASSESSED AT A GREATER RATE. THE SECOND HOUR OR FRACTION THEREOF WILL BE ASSESSED AT THE RATE OF \$2,600.00 PER HOUR. THE THIRD HOUR OR FRACTION THEREOF AND ALL ADDITIONAL HOURS SHALL BE ASSESSED AT THE RATE \$4,000.00 PER HOUR.

THE CONTRACTOR SHALL SHIFT TRAFFIC TO THE ULTIMATE CONFIGURATION WITH THREE LANES IN EACH DIRECTION OPEN TO TRAFFIC PRIOR TO AUGUST 1, 2016. THE FINAL SURFACE COURSE WILL NOT BE REQUIRED TO BE PLACED AT THIS TIME. THE FIXED COMPLETION DATE FOR THE PROJECT WILL BE SEPTEMBER 30, 2016. LIQUIDATED DAMAGES WILL BE ASSESSED AS OUTLINED IN THE KENTUCKY STANDARD SPECIFICATIONS FOR ROAD AND BRIDGE CONSTRUCTION CURRENT EDITION FOR FAILURE TO COMPLETE THE WORK IN THE TIME ALLOWED.

TRAFFIC CONTROL COORDINATOR

THE CONTRACTOR SHALL DESIGNATE AN EMPLOYEE OR EMPLOYEES TO BE TRAFFIC CONTROL COORDINATOR(S). THE TRAFFIC CONTROL COORDINATOR SHALL INSPECT THE PROJECT MAINTENANCE OF TRAFFIC AT LEAST TWICE A DAY, FOR THE LIFE OF THE PROJECT. ADDITIONALLY, THE TRAFFIC CONTROL COORDINATOR SHALL REPORT ALL INCIDENTS THROUGHOUT THE WORK ZONE TO THE ENGINEER ON THE PROJECT. A TRAFFIC CONTROL COORDINATOR SHALL BE ON THE PROJECT AT ALL TIMES WHEN LANE CLOSURES ARE IN USE TO INSPECT THE TRAFFIC CONTROL, MAINTAIN THE SIGNING AND DEVICES AND RELOCATE VARIABLE MESSAGE BOARDS AS NEEDED OR AS DIRECTED BY THE ENGINEER. A TRAFFIC CONTROL COORDINATOR SHALL BE ON CALL 24 HOURS A DAY, 7 DAYS A WEEK FOR THE PROJECT DURATION. THE TRAFFIC CONTROL COORDINATOR SHALL BE RESPONSIBLE FOR TRAFFIC CONTROL MAINTENANCE AND SHALL MAKE AT LEAST ONE PASS-THROUGH INSPECTION ON THE PROJECT PER HOUR AT ALL TIMES LANES ARE CLOSED. THE CONTRACTOR SHALL FURNISH THE NAME AND TELEPHONE NUMBER WHERE THE TRAFFIC CONTROL COORDINATOR CAN BE CONTACTED AT ANY TIME. THE TRAFFIC CONTROL COORDINATOR SHALL HAVE ACCESS ON THE PROJECT TO A RADIO OR TELEPHONE TO BE USED IN CASE OF EMERGENCIES OR ACCIDENTS. THE TRAFFIC CONTROL COORDINATOR SHALL BE PAID FOR AT THE LUMP SUM BID FOR "MAINTAIN AND CONTROL TRAFFIC".

FOR MAINTENANCE OF TRAFFIC ONLY

MAINTENANCE OF TRAFFIC NOTES

FILE NAME: U:\1113\FINAL PLAN SUBMITTAL\FINAL CONTRACT PLANS\CONTRACT PLAN SET\ROADWAY\ROADWAY PLANS\RS05600MT.DGN

USER: Joshua.compleas
DATE PLOTTED: November 14, 2014

E-SHEET NAME:

MicroStation v8.11.9.397

MAINTENANCE OF TRAFFIC NOTES

GENERAL NOTES

ALL TRAFFIC CONTROL DEVICES SHALL COMPLY WITH THE CURRENT KYTC STANDARD DRAWINGS AND THE CURRENT MANUAL ON UNIFORM TRAFFIC CONTROL DEVICES (MUTCD).

OTHER MAINTENANCE OF TRAFFIC PROPOSALS WILL BE CONSIDERED IN ACCORDANCE WITH THE STANDARD SPECIFICATIONS; HOWEVER, ALTERNATE MAINTENANCE OF TRAFFIC SCHEMES WILL NOT BE SUBJECT TO VALUE ENGINEERING UNDER SECTION III.

IF THE CONTRACTOR DECIDES TO DEVIATE FROM THE TRAFFIC CONTROL SCHEME AND CONSTRUCTION SCHEDULE OUTLINED IN THESE PLANS OR PROPOSAL, AN ALTERNATE PLAN SHALL BE SUBMITTED IN WRITING TO THE PROJECT ENGINEER. THE ALTERNATE PLAN MAY BE USED ONLY IF APPROVED IN WRITING BY THE KENTUCKY DIVISION OF DESIGN, TRAFFIC, AND CONSTRUCTION.

THE REQUIREMENTS FOR ALTERNATE MAINTENANCE OF TRAFFIC SCHEMES ON NEW CIRCLE ROAD SHALL BE AT LEAST 11 FOOT LANES FOR THRU TRAFFIC. TWO LANES PER DIRECTION SHALL BE OPEN TO TRAFFIC AT ALL TIMES, UNLESS OTHERWISE SPECIFIED IN THE MAINTENANCE OF TRAFFIC PLANS.

THE CONTRACTOR SHALL SUBMIT IN WRITING, PLANS FOR APPROVAL BY THE DEPARTMENT BEFORE STOPPING TRAFFIC.

NORMAL CONSIDERATION SHOULD BE GIVEN TO PROPERTY OWNERS FOR THEIR ACCESS.

REPAIR AND/OR UPGRADE PAVEMENT ALONG AND ACROSS EXISTING ROADS WHERE CONSTRUCTION TRAFFIC CROSSES. ACCESS TO ALL PUBLIC ROADS IS TO BE MAINTAINED EXCEPT AS INDICATED IN THE MAINTENANCE OF TRAFFIC NOTES.

CONSTRUCT EROSION CONTROLS AT POINTS WHERE RUNOFF LEAVES THE PROJECT SITE. BEGIN EARTHWORK, UTILIZING TEMPORARY DIVERSION DITCHES TO DIRECT RUNOFF TO EROSION CONTROLS.

THE CONTRACTOR MUST NOTIFY THE PROJECT ENGINEER WITHIN THE FOLLOWING TIME FRAMES OF PENDING CHANGES IN THEIR WORK SCHEDULE WHICH WILL AFFECT TRAFFIC PATTERNS:

- 1) AT LEAST FOURTEEN (14) DAYS PRIOR TO BEGINNING CONSTRUCTION PHASES
- 2) AT LEAST FIVE (5) DAYS PRIOR TO A LANE OR RAMP CLOSURE
- 3) IF A DECISION IS MADE NOT TO CLOSE A LANE OR RAMP, NOTICE MUST BE GIVEN TO THE PROJECT ENGINEER 5 DAYS PRIOR TO THE PROPOSED CLOSURE.

EXCEPT FOR THE ROADWAY AND TRAFFIC CONTROL BID ITEMS LISTED, ALL ITEMS OF WORK NECESSARY TO MAINTAIN AND CONTROL TRAFFIC WILL BE PAID FOR AT THE LUMP SUM BID PRICE OF "MAINTAIN & CONTROL TRAFFIC", AS SET FORTH IN THE CURRENT STANDARD SPECIFICATIONS FOR ROAD AND BRIDGE CONSTRUCTION, UNLESS OTHERWISE PROVIDED FOR IN THESE NOTES.

SPECIAL NOTES

AT ALL TIMES THE CONTRACTOR SHALL WORK IN THE DESIGNATED WORK AREAS. THE CONTRACTOR SHALL NOT PERFORM EXCAVATIONS OR RUN EQUIPMENT OUTSIDE THE ROADWAY DURING THE MEDIAN CONSTRUCTION STAGE UNLESS SO DESIGNATED IN THE PLANS. DURING TIMES WHEN TRAFFIC IS LIMITED TO ONE LANE IN ANY DIRECTION (I.E. GRINDING/STRIPING FOR PHASING TRANSITION, PLACING TEMPORARY CONCRETE BARRIER, ETC) WORK SHALL ONLY BE PERFORMED DURING LOW VOLUME TRAFFIC HOURS.

THE CONTRACTOR'S VEHICLES SHALL ALWAYS MOVE WITH, AND NOT AGAINST, THE FLOW OF TRAFFIC. VEHICLES SHALL ENTER AND LEAVE WORK AREAS IN A MANNER WHICH WILL NOT INTERFERE WITH NORMAL TRAFFIC. VEHICLES SHALL NOT PARK OR STOP EXCEPT WITHIN WORK AREAS DESIGNATED BY THE PROJECT ENGINEER.

THE CONTRACTOR WILL NOT BE ALLOWED TO HAUL EQUIPMENT OR DRIVE ACROSS THE MEDIAN FROM ONE SIDE OF NEW CIRCLE ROAD TO THE OTHER UNLESS APPROPRIATE BARRIER WALL GATES HAVE BEEN INSTALLED. ALL OTHER EQUIPMENT MOVEMENTS FROM ONE SIDE OF NEW CIRCLE ROAD TO THE OTHER SHALL UTILIZE THE NEAREST INTERCHANGE. HAULING EQUIPMENT THAT USES NEW CIRCLE ROAD SHALL BE RESTRICTED TO LICENSED VEHICLES ONLY. VEHICLES SHALL NOT STOP OR PARK IN AREAS NOT DESIGNATED BY THE PROJECT ENGINEER. ANY SHOULDER USED FOR A DECELERATION OR ACCELERATION LANE SHALL BE WIDENED AND PAVED TO ADEQUATELY SUPPORT HEAVY TRUCK TRAFFIC. ALL EXPENSES INCURRED TO CONSTRUCT BARRIER WALL GATES AND REMOVAL THERE OF SHALL BE BORNE BY THE CONTRACTOR AND BE INCIDENTAL TO THE CONTRACT. PAVEMENT NEEDED TO CONSTRUCT BARRIER WALL GATES WILL BE MEASURED FOR PAYMENT.

THE CONTRACTOR SHALL NOTIFY FAYETTE COUNTY 911 SERVICE TWO WEEKS PRIOR TO ROAD CLOSURES.

WHEN SETTING BEAMS, REMOVING OR CONSTRUCTING OVERHEAD SIGN SUPPORTS, AND CHANGING FROM ONE TRAFFIC PATTERN TO ANOTHER, TRAFFIC MAY BE HALTED AT THE NEAREST INTERCHANGE FOR A PERIOD NOT TO EXCEED 30 MINUTES. ROAD CLOSURES SHALL BE ALLOWED ONLY DURING THE HOURS OF MINIMUM TRAFFIC VOLUMES AS DESCRIBED IN THESE TRAFFIC CONTROL NOTES.

LAW ENFORCEMENT OFFICERS (LEO'S)

POLICE SUPPORT SHALL BE A UNIT CONSISTING OF AN OFF-DUTY POLICEMAN FROM ANY POLICE FORCE AGENCY HAVING LAWFUL JURISDICTION AND A POLICE CAR EQUIPPED WITH EXTERNALLY MOUNTED BLUE LIGHTS. IT IS ANTICIPATED THAT APPROXIMATELY TWO (2) OFFICERS WILL BE REQUIRED FOR EACH CLOSURE SET UP. THE OFFICER(S) WILL BE PLACED AT THE DISCRETION OF THE PROJECT ENGINEER.

HOURS OF LOW TRAFFIC VOLUMES

IN THESE NOTES AND FOLLOWING SEQUENCE OF CONSTRUCTION, THE PHRASE "HOURS OF LOW TRAFFIC VOLUMES" IS USED TO SPECIFY A PERIOD OF TIME IN WHICH A LANE CLOSURE MAY BE INSTALLED FOR CONSTRUCTION OPERATIONS ADJACENT TO A TRAVELED WAY. LISTED BELOW ARE THE HOURS OF LOW TRAFFIC VOLUMES.

SOUTHBOUND	NORTHBOUND
MON 7:00 PM - TUE 7:00 AM	MON 7:00 PM - TUE 7:00 AM
TUE 7:00 PM - WED 7:00 AM	TUE 7:00 PM - WED 7:00 AM
WED 7:00 PM - THU 7:00 AM	WED 7:00 PM - THU 7:00 AM
THU 7:00 PM - FRI 7:00 AM	THU 7:00 PM - FRI 7:00 AM
FRI 8:00 PM - SAT 7:00 AM	FRI 8:00 PM - SAT 7:00 AM
SAT 7:00 PM - SUN 7:00 AM	SAT 7:00 PM - SUN 7:00 AM
SUN 7:00 PM - MON 7:00 AM	SUN 7:00 PM - MON 7:00 AM

PRIOR TO THE CONTRACTOR PERFORMING ANY CONSTRUCTION SEQUENCE, HE MUST APPLY IN WRITING TO THE PROJECT ENGINEER FOR APPROVAL OF THE PERIOD OF TIME SELECTED. THE PROJECT ENGINEER, AT HIS DISCRETION, CAN CANCEL OR SHORTEN ANY PERIOD OF TIME BEFORE AND DURING A CONSTRUCTION SEQUENCE. IF THE PROJECT ENGINEER SHORTENS A PERIOD OF TIME BEFORE AND DURING A CONSTRUCTION SEQUENCE, THE CONTRACTOR SHALL REMOVE ALL EQUIPMENT AND INSTALL PROPER TRAFFIC CONTROL DEVICES.

HOURS OF MINIMUM TRAFFIC VOLUMES

IN THESE NOTES AND FOLLOWING SEQUENCE OF CONSTRUCTION, THE PHRASE "HOURS OF MINIMUM TRAFFIC VOLUMES" IS USED TO SPECIFY A TIME FRAME IN WHICH A ROADWAY CAN BE COMPLETELY CLOSED BETWEEN TWO (2) ADJACENT INTERCHANGES IN ORDER TO PERFORM A PARTICULAR CONSTRUCTION SEQUENCE. LISTED BELOW ARE PERIODS OF TIME EACH WEEK THAT ARE CONSIDERED "HOURS OF MINIMUM TRAFFIC VOLUMES".

SOUTHBOUND	NORTHBOUND
MON 10:00 PM - TUE 5:00 AM	MON 10:00 PM - TUE 5:00 AM
TUE 10:00 PM - WED 5:00 AM	TUE 10:00 PM - WED 5:00 AM
WED 10:00 PM - THU 5:00 AM	WED 10:00 PM - THU 5:00 AM
THU 10:00 PM - FRI 5:00 AM	THU 10:00 PM - FRI 5:00 AM
FRI MIDNIGHT - SAT 5:00 AM	FRI MIDNIGHT - SAT 5:00 AM
SAT MIDNIGHT - SUN 5:00 AM	SAT MIDNIGHT - SUN 5:00 AM
SUN MIDNIGHT - MON 5:00 AM	SUN MIDNIGHT - MON 5:00 AM

THE TIME A CONTRACTOR CAN COMPLETELY CLOSE DOWN THE ROADWAY SHALL NOT EXCEED 30 MINUTES. THESE INTERRUPTIONS TO TRAFFIC SHALL NOT OCCUR UNLESS TRAFFIC HAS BEEN RESTORED IN THE OPINION OF THE PROJECT ENGINEER FROM A PRIOR CLOSURE. BLASTING OPERATIONS WILL NOT BE ALLOWED FOR THE TIMES LISTED ABOVE.

OLD FRANKFORT PIKE AND INTERCHANGE RAMP CLOSURES

UNLESS APPROVED DURING THE LOW TRAFFIC AND MINIMUM TRAFFIC HOURS LISTED, TRAFFIC SHALL BE MAINTAINED ON OLD FRANKFORT PIKE AND INTERCHANGE RAMP AT ALL TIMES WITH THE FOLLOWING EXCEPTION. THE CONTRACTOR WILL BE ALLOCATED ONE WEEKEND FOR CLOSURE OF RAMP D, E, F, AND OLD FRANKFORT PIKE AND ONE WEEKEND FOR CLOSURE OF RAMP A, B, C, AND OLD FRANKFORT PIKE (WHILE MAINTAINING ACCESS TO DUNCAN MACHINERY DRIVE) WITH SAID WEEKEND BEGINNING AT 7:00 PM FRIDAY AND ENDING AT 6:00 AM MONDAY. ANY CLOSURE IN PLACE BEYOND 6:00 AM MONDAY WILL BE ASSESSED LIQUIDATED DAMAGES AT THE RATES LISTED UNDER LIQUIDATED DAMAGES AND DISINCENTIVES.

HOLIDAYS AND SPECIAL EVENTS

LISTED BELOW ARE DATES AND TIMES FOR HOLIDAYS AND SPECIAL EVENTS WHEN ROAD CLOSURES, LANE CLOSURES AND BLASTING WILL NOT BE ALLOWED.

2014	
THANKSGIVING	6:00 AM NOVEMBER 26 TO 6:00 AM DECEMBER 1
CHRISTMAS	6:00 PM DECEMBER 23 TO 6:00 AM DECEMBER 26
NEW YEARS	6:00 PM DECEMBER 31 TO 6:00 AM JANUARY 3
2015	
KEA (SPRING BREAK)	TO BE DETERMINED BY THE DEPARTMENT
EASTER	6:00 AM APRIL 3 TO 6:00 AM APRIL 6
MEMORIAL DAY	6:00 AM MAY 21 TO 6:00 AM MAY 26
JULY 4TH	6:00 AM JULY 1 TO 6:00 AM JULY 6
LABOR DAY	6:00 AM SEPTEMBER 4 TO 6:00 AM SEPTEMBER 8
THANKSGIVING	6:00 AM NOVEMBER 25 TO 6:00 AM NOVEMBER 30
CHRISTMAS	6:00 PM DECEMBER 23 TO 6:00 AM DECEMBER 27
NEW YEARS	6:00 PM DECEMBER 30 TO 6:00 AM JANUARY 3
2016	
KEA (SPRING BREAK)	TO BE DETERMINED BY THE DEPARTMENT
EASTER	6:00 AM MARCH 25 TO 6:00 AM MARCH 28
MEMORIAL DAY	6:00 AM MAY 27 TO 6:00 AM MAY 31
JULY 4TH	6:00 AM JULY 1 TO 6:00 AM JULY 5
LABOR DAY	6:00 AM SEPTEMBER 2 TO 6:00 AM SEPTEMBER 6

FUTURE HOLIDAY DATES SHALL BE DETERMINED BY THE DEPARTMENT IF NECESSARY, COMPARABLE TO ABOVE DATES. THE ABOVE DATES ARE SUBJECT TO CHANGE IF THE DEPARTMENT DEEMS NECESSARY.

SPEED LIMIT

THE SPEED LIMIT ON NEW CIRCLE ROAD WILL BE REDUCED TO 45 MPH IN THE WORK ZONE. REDUCED SPEED AHEAD SIGNS (R2-A) AND 45 MPH SIGNS (R2-I) SHALL BE INSTALLED BOTH NORTHBOUND AND SOUTHBOUND. PAYMENT FOR THESE SIGNS SHALL BE IN THE BID ITEM SIGNS - CODE 2562.

THE SPEED LIMIT ON ALL OTHER ROADWAYS WILL BE REDUCED AS NOTED IN THE FOLLOWING PLANS. REDUCED SPEED AHEAD SIGNS (R2-A) AND SPEED LIMIT MPH SIGNS (R2-I) SHALL BE INSTALLED IN BOTH TRAVEL DIRECTIONS. PAYMENT FOR THESE SIGNS SHALL BE IN THE BID ITEM SIGNS - CODE 2562.

BLASTING OPERATIONS

DURING BLASTING OPERATIONS, TRAFFIC IN BOTH DIRECTIONS MAY BE HALTED A MAXIMUM OF 15 MINUTES PER HOUR TO ALLOW THE EXECUTION OF THE "SHOT" AND TO ALLOW FOR REMOVAL OF ROCK FRAGMENTS AND DEBRIS. WHEN USING EXPLOSIVE CHARGES OF ANY KIND FOR THE PURPOSE OF EXCAVATING, THE CONTRACTOR SHALL HALT ALL TRAFFIC A SAFE DISTANCE ON EITHER SIDE OF THE IMPENDING EXPLOSION. THE CONTRACTOR SHALL IMMEDIATELY INSPECT THE PAVEMENTS FOR ANY DEBRIS THAT MAY BE A HAZARD TO TRAFFIC BEFORE ALLOWING TRAFFIC TO PROCEED ON THE AFFECTED SECTION. WHEN BLASTING, THE CONTRACTOR SHALL HALT TRAFFIC, BLAST, CLEAN THE EXISTING PAVEMENTS AND RETURN TRAFFIC TO NORMAL OPERATION IN THE LEAST AMOUNT OF TIME AS POSSIBLE.

LISTED BELOW ARE THE PERIODS OF TIME FOR EACH DAY OF THE WEEK TRAFFIC HALTS FOR BLASTING WILL BE ALLOWED:

MONDAY	9:00 AM TO 2:00 PM
TUESDAY	9:00 AM TO 2:00 PM
WEDNESDAY	9:00 AM TO 2:00 PM
THURSDAY	9:00 AM TO 2:00 PM
FRIDAY	9:00 AM TO 2:00 PM

LIQUIDATED DAMAGES AND DISINCENTIVES

THE FOLLOWING DAMAGES SHALL BE ASSESSED IF ROAD CLOSURES ARE KEPT FOR LONGER THAN 15 MINUTES DURING BLASTING OPERATIONS:

15 TO 30 MINUTES	\$10,000.00
30 TO 45 MINUTES	\$20,000.00
45 TO 60 MINUTES	\$40,000.00

ALL ROAD CLOSURES LEFT IN PLACE FOR MORE THAN 60 MINUTES WILL BE ASSESSED DAMAGES OF \$40,000.00 PER HOUR OR FRACTION THEREOF. DAMAGES FOR ANY FRACTION OF AN HOUR WILL BE CHARGED AT THE FULL \$40,000.00 HOURLY RATE. INTERRUPTIONS TO TRAFFIC SHALL NOT OCCUR MORE THAN ONCE IN A PERIOD OF PERMITTED ROAD CLOSURE UNLESS NORMAL TRAFFIC FLOW HAS BEEN RESTORED AND THE PROJECT ENGINEER APPROVES ANOTHER ROAD CLOSURE.

THE CONTRACTOR SHALL SUBMIT IN WRITING PLANS FOR STOPPING TRAFFIC WHICH WILL BE REVIEWED BY THE DEPARTMENT OF HIGHWAYS.

DISINCENTIVES OF \$1,300.00 PER LANE CLOSURE PER HOUR WILL BE CHARGED EACH HOUR OR FRACTION OF AN HOUR THAT TWO LANES IN EACH DIRECTION OF NEW CIRCLE ROAD ARE NOT OPEN EXCEPT FOR PERMITTED HOURS DURING HOURS OF LOW TRAFFIC VOLUME. THE \$1,300.00 DISINCENTIVE SHALL ALSO APPLY TO ANY SINGLE LANE OF TRAFFIC NOT SPECIFICALLY PERMITTED IN THE TRAFFIC CONTROL PLAN. LANE CLOSURES IN PLACE FOR MORE THAN ONE HOUR IN EXCESS OF PERMITTED HOURS WILL BE ASSESSED AT A GREATER RATE. THE SECOND HOUR OR FRACTION THEREOF WILL BE ASSESSED AT THE RATE OF \$2,600.00 PER HOUR. THE THIRD HOUR OR FRACTION THEREOF AND ALL ADDITIONAL HOURS SHALL BE ASSESSED AT THE RATE \$4,000.00 PER HOUR.

THE CONTRACTOR SHALL SHIFT TRAFFIC TO THE ULTIMATE CONFIGURATION WITH THREE LANES IN EACH DIRECTION OPEN TO TRAFFIC PRIOR TO AUGUST 1, 2016. THE FINAL SURFACE COURSE WILL NOT BE REQUIRED TO BE PLACED AT THIS TIME. THE FIXED COMPLETION DATE FOR THE PROJECT WILL BE SEPTEMBER 30, 2016. LIQUIDATED DAMAGES WILL BE ASSESSED AS OUTLINED IN THE KENTUCKY STANDARD SPECIFICATIONS FOR ROAD AND BRIDGE CONSTRUCTION CURRENT EDITION FOR FAILURE TO COMPLETE THE WORK IN THE TIME ALLOWED.

TRAFFIC CONTROL COORDINATOR

THE CONTRACTOR SHALL DESIGNATE AN EMPLOYEE OR EMPLOYEES TO BE TRAFFIC CONTROL COORDINATOR(S). THE TRAFFIC CONTROL COORDINATOR SHALL INSPECT THE PROJECT MAINTENANCE OF TRAFFIC AT LEAST TWICE A DAY, FOR THE LIFE OF THE PROJECT. ADDITIONALLY, THE TRAFFIC CONTROL COORDINATOR SHALL REPORT ALL INCIDENTS THROUGHOUT THE WORK ZONE TO THE ENGINEER ON THE PROJECT. A TRAFFIC CONTROL COORDINATOR SHALL BE ON THE PROJECT AT ALL TIMES WHEN LANE CLOSURES ARE IN USE TO INSPECT THE TRAFFIC CONTROL, MAINTAIN THE SIGNING AND DEVICES AND RELOCATE VARIABLE MESSAGE BOARDS AS NEEDED OR AS DIRECTED BY THE ENGINEER. A TRAFFIC CONTROL COORDINATOR SHALL BE ON CALL 24 HOURS A DAY, 7 DAYS A WEEK FOR THE PROJECT DURATION. THE TRAFFIC CONTROL COORDINATOR SHALL BE RESPONSIBLE FOR TRAFFIC CONTROL MAINTENANCE AND SHALL MAKE AT LEAST ONE PASS-THROUGH INSPECTION ON THE PROJECT PER HOUR AT ALL TIMES LANES ARE CLOSED. THE CONTRACTOR SHALL FURNISH THE NAME AND TELEPHONE NUMBER WHERE THE TRAFFIC CONTROL COORDINATOR CAN BE CONTACTED AT ANY TIME. THE TRAFFIC CONTROL COORDINATOR SHALL HAVE ACCESS ON THE PROJECT TO A RADIO OR TELEPHONE TO BE USED IN CASE OF EMERGENCIES OR ACCIDENTS. THE TRAFFIC CONTROL COORDINATOR SHALL BE PAID FOR AT THE LUMP SUM BID FOR "MAINTAIN AND CONTROL TRAFFIC".

FOR MAINTENANCE OF TRAFFIC ONLY

MAINTENANCE OF TRAFFIC NOTES

FILE NAME: U:\1113\FINAL PLAN SUBMITTAL\FINAL CONTRACT PLANS\CONTRACT PLAN SET\ROADWAY\ROADWAY PLANS\RS05600MT.DGN
 USER: joshua.comple
 DATE PLOTTED: November 14, 2014
 E-SHEET NAME:
 MicroStation v8.11.9.397

MATERIAL SUMMARY

CONTRACT ID: 141291

121GR14D091-NHPP & JL04

DE03400041490

US 60 AND KY 4 (NEW CIRCLE ROAD) INTERCHANGE RECONSTRUCTION OF KY-4 / US60 (VERSAILLES ROAD) INTERCHANGE BRIDGE WITH GRADE, DRAIN & SURFACE, A DISTANCE OF .8 MILES.

Project Line No	Bid Code	DESCRIPTION	Quantity	Unit
0360	00001	DGA BASE	16,916.00	TON
0361	00190	LEVELING & WEDGING PG64-22	8,997.00	TON
0362	00193	ASPHALT SCRATCH COURSE PG76-22	358.00	TON
0363	00212	CL2 ASPH BASE 1.00D PG64-22	6,415.00	TON
0364	00214	CL3 ASPH BASE 1.00D PG64-22	10,336.00	TON
0365	00216	CL3 ASPH BASE 1.00D PG76-22	9,733.00	TON
0366	00301	CL2 ASPH SURF 0.38D PG64-22	2,051.00	TON
0367	00336	CL3 ASPH SURF 0.38A PG76-22	5,285.00	TON
0368	01820	LIP CURB AND GUTTER	3,471.00	LF
0369	01890	ISLAND HEADER CURB TYPE 1	1,902.00	LF
0370	01947	MOUNTABLE MEDIAN TYPE 3A	247.00	SQYD
0371	01949	MOUNTABLE MEDIAN TYPE 6A	277.00	SQYD
0372	02677	ASPHALT PAVE MILLING & TEXTURING	2,975.00	TON
0373	00078	CRUSHED AGGREGATE SIZE NO 2	13.00	TON
0374	01000	PERFORATED PIPE-4 IN	3,090.00	LF
0375	01010	NON-PERFORATED PIPE-4 IN	66.50	LF
0376	01015	INSPECT & CERTIFY EDGE DRAIN SYSTEM - (7-279)	1.00	LS
0377	01020	PERF PIPE HEADWALL TY 1-4 IN	1.00	EACH
0378	01028	PERF PIPE HEADWALL TY 3-4 IN	11.00	EACH
0379	01310	REMOVE PIPE	217.00	LF
0380	01706	REMOVE CATCH BASIN	16.00	EACH
0381	01740	CORED HOLE DRAINAGE BOX CON-4 IN	6.00	EACH
0382	01904	REMOVE CURB	16,027.00	LF
0383	01982	DELINEATOR FOR GUARDRAIL MONO DIRECTIONAL WHITE	38.00	EACH
0384	01983	DELINEATOR FOR GUARDRAIL MONO DIRECTIONAL YELLOW	17.00	EACH
0385	01986	DELINEATOR FOR BARRIER WALL-B/Y	8.00	EACH
0386	01990	DELINEATOR FOR BARRIER WALL-B/W	10.00	EACH
0387	02014	BARRICADE-TYPE III	12.00	EACH
0388	02091	REMOVE PAVEMENT	3,848.00	SQYD
0389	02157	PAVED DITCH TYPE 1	107.00	SQYD
0390	02159	TEMP DITCH	38,356.00	LF
0391	02160	CLEAN TEMP DITCH	115,068.00	LF
0392	02165	REMOVE PAVED DITCH	558.00	SQYD
0393	02200	ROADWAY EXCAVATION	39,493.00	CUYD
0394	02203	STRUCTURE EXCAV-UNCLASSIFIED	188.00	CUYD
0395	02223	GRANULAR EMBANKMENT	200.00	CUYD
0396	02235	BACKFILLING UNDERCUT	200.00	CUYD
0397	02242	WATER - (FOR DUST CONTROL)	500.00	MGAL
0398	02352	GUARDRAIL-STEEL W BEAM-D FACE	50.00	LF
0399	02363	GUARDRAIL CONNECTOR TO BRIDGE END TY A	4.00	EACH
0400	02364	GUARDRAIL TERMINAL SECTION NO 2	5.00	EACH
0401	02367	GUARDRAIL END TREATMENT TYPE 1	11.00	EACH

MATERIAL SUMMARY

Project Line No	Bid Code	DESCRIPTION	Quantity	Unit
0402	02369	GUARDRAIL END TREATMENT TYPE 2A	12.00	EACH
0403	02381	REMOVE GUARDRAIL	7,182.70	LF
0404	02387	GUARDRAIL CONNECTOR TO BRIDGE END TY A-1	1.00	EACH
0405	02483	CHANNEL LINING CLASS II	121.90	TON
0406	02484	CHANNEL LINING CLASS III	33.00	TON
0407	02545	CLEARING AND GRUBBING - (APPROXIMATELY 30 ACRES, 7-279)	1.00	LS
0408	02555	CONCRETE-CLASS B	194.00	CUYD
0409	02562	TEMPORARY SIGNS	941.50	SQFT
0410	02596	FABRIC-GEOTEXTILE TYPE I	227.70	SQYD
0411	02599	FABRIC-GEOTEXTILE TYPE IV	200.00	SQYD
0412	02600	FABRIC GEOTEXTILE TY IV FOR PIPE	2,652.00	SQYD
0413	02625	REMOVE HEADWALL	23.00	EACH
0414	02650	MAINTAIN & CONTROL TRAFFIC - (7-279)	1.00	LS
0415	02651	DIVERSIONS (BY-PASS DETOURS) - (#1, 7-279)	1.00	LS
0416	02651	DIVERSIONS (BY-PASS DETOURS) - (#2, 7-279)	1.00	LS
0417	02651	DIVERSIONS (BY-PASS DETOURS) - (#3, 7-279)	1.00	LS
0418	02651	DIVERSIONS (BY-PASS DETOURS) - (#4, 7-279)	1.00	LS
0419	02671	PORTABLE CHANGEABLE MESSAGE SIGN	4.00	EACH
0420	02676	MOBILIZATION FOR MILL & TEXT - (7-279)	1.00	LS
0421	02690	SAFELOADING	24.60	CUYD
0422	02701	TEMP SILT FENCE	38,356.00	LF
0423	02703	SILT TRAP TYPE A	60.00	EACH
0424	02704	SILT TRAP TYPE B	60.00	EACH
0425	02705	SILT TRAP TYPE C	60.00	EACH
0426	02706	CLEAN SILT TRAP TYPE A	180.00	EACH
0427	02707	CLEAN SILT TRAP TYPE B	180.00	EACH
0428	02708	CLEAN SILT TRAP TYPE C	180.00	EACH
0429	02709	CLEAN TEMP SILT FENCE	115,068.00	LF
0430	02726	STAKING - (7-279)	1.00	LS
0431	02775	ARROW PANEL	6.00	EACH
0432	03171	CONCRETE BARRIER WALL TYPE 9T	600.00	LF
0433	03225	TUBULAR MARKERS	120.00	EACH
0434	05950	EROSION CONTROL BLANKET	6,653.00	SQYD
0435	05952	TEMP MULCH	288,464.00	SQYD
0436	05953	TEMP SEEDING AND PROTECTION	85,000.00	SQYD
0437	05963	INITIAL FERTILIZER	6.40	TON
0438	05964	20-10-10 FERTILIZER	10.70	TON
0439	05985	SEEDING AND PROTECTION	206,184.00	SQYD
0440	05992	AGRICULTURAL LIMESTONE	127.80	TON
0441	06401	FLEXIBLE DELINEATOR POST-M/W	187.00	EACH
0442	06404	FLEXIBLE DELINEATOR POST-M/Y	88.00	EACH
0443	06510	PAVE STRIPING-TEMP PAINT-4 IN	16,600.00	LF
0444	06511	PAVE STRIPING-TEMP PAINT-6 IN	57,700.00	LF
0445	06514	PAVE STRIPING-PERM PAINT-4 IN - (WHITE)	14,162.00	LF
0446	06514	PAVE STRIPING-PERM PAINT-4 IN - (YELLOW)	13,157.00	LF
0447	06516	PAVE STRIPING-PERM PAINT-8 IN - (WHITE)	1,430.00	LF
0448	06531	PAVE STRIPING REMOVAL-6 IN	14,100.00	LF
0449	06565	PAVE MARKING-THERMO X-WALK-6 IN	1,097.00	LF
0450	06568	PAVE MARKING-THERMO STOP BAR-24IN	255.00	LF

MATERIAL SUMMARY

Project Line No	Bid Code	DESCRIPTION	Quantity	Unit
0451	06574	PAVE MARKING-THERMO CURV ARROW	45.00	EACH
0452	06576	PAVE MARKING-THERMO ONLY	7.00	EACH
0453	06589	PAVEMENT MARKER TYPE V-MW	287.00	EACH
0454	06592	PAVEMENT MARKER TYPE V-B W/R	242.00	EACH
0455	06593	PAVEMENT MARKER TYPE V-B Y/R	211.00	EACH
0456	06600	REMOVE PAVEMENT MARKER TYPE V	160.00	EACH
0457	08900	CRASH CUSHION TY VI CLASS B TL2	1.00	EACH
0458	08904	CRASH CUSHION TY VI CLASS C	4.00	EACH
0459	10020NS	FUEL ADJUSTMENT	75,396.00	DOLL
0460	10030NS	ASPHALT ADJUSTMENT	101,015.00	DOLL
0461	20259ED	TEMPORARY MEDIAN CROSSOVER	2.00	EACH
0462	20411ED	LAW ENFORCEMENT OFFICER	3,000.00	HOURL
0463	21342ED	FORM LINER	2,514.00	SQFT
0464	21370ED	LONGITUDINAL SAW CUT- 6 IN	9,861.00	LF
0465	21802EN	G/R STEEL W BEAM-S FACE (7 FT POST)	3,850.00	LF
0466	23131ER701	PIPELINE VIDEO INSPECTION	1,650.00	LF
0467	23274EN11F	TURF REINFORCEMENT MAT 1	4,850.00	SQYD
0468	24035EC	CONC MED BAR END FOR CRASH CUSHION TY IX	1.00	EACH
0469	24189ER	DURABLE WATERBORNE MARKING-6 IN W	12,953.00	LF
0470	24190ER	DURABLE WATERBORNE MARKING-6 IN Y	9,069.00	LF
0471	24191ER	DURABLE WATERBORNE MARKING-12 IN W	4,162.00	LF
0472	00462	CULVERT PIPE-18 IN	87.00	LF
0473	00464	CULVERT PIPE-24 IN	476.00	LF
0474	00466	CULVERT PIPE-30 IN	82.00	LF
0475	00469	CULVERT PIPE-42 IN	24.00	LF
0476	00494	CULVERT PIPE-30 IN EQUIV	48.00	LF
0477	00521	STORM SEWER PIPE-15 IN	744.00	LF
0478	00522	STORM SEWER PIPE-18 IN	76.00	LF
0479	00524	STORM SEWER PIPE-24 IN	192.00	LF
0480	01202	PIPE CULVERT HEADWALL-15 IN	3.00	EACH
0481	01208	PIPE CULVERT HEADWALL-24 IN	2.00	EACH
0482	01210	PIPE CULVERT HEADWALL-30 IN	1.00	EACH
0483	01214	PIPE CULVERT HEADWALL-42 IN	1.00	EACH
0484	01373	METAL END SECTION TY 1-24 IN	1.00	EACH
0485	01432	SLOPED BOX OUTLET TYPE 1-15 IN	1.00	EACH
0486	01433	SLOPED BOX OUTLET TYPE 1-18 IN	3.00	EACH
0487	01434	SLOPED BOX OUTLET TYPE 1-24 IN - EQUIVALENT	1.00	EACH
0488	01440	SLOPED BOX INLET-OUTLET TYPE 1	4.00	EACH
0489	01456	CURB BOX INLET TYPE A	3.00	EACH
0490	01480	CURB BOX INLET TYPE B	2.00	EACH
0491	01490	DROP BOX INLET TYPE 1	5.00	EACH
0492	01559	DROP BOX INLET TYPE 13G	3.00	EACH
0493	01584	CAP DROP BOX INLET	2.00	EACH
0494	01585	REMOVE DROP BOX INLET	1.00	EACH
0495	01650	JUNCTION BOX	1.00	EACH
0496	01651	JUNCTION BOX-MOD	1.00	EACH
0497	01719	ADJUST INLET	3.00	EACH
0498	01720	RECONSTRUCT INLET	2.00	EACH
0499	21799EN	BORE AND JACK PIPE-24 IN	180.00	LF
0500	22628NN	DROP BOX INLET-MOD	1.00	EACH

MATERIAL SUMMARY

Project Line No	Bid Code	DESCRIPTION	Quantity	Unit
0501	23126EN	BORE AND JACK PIPE-18 IN	76.00	LF
0502	24575ES610	HEADWALL - (DOUBLE STANDARD, 24")	1.00	EACH
0503	08100	CONCRETE-CLASS A	183.10	CUYD
0504	08104	CONCRETE-CLASS AA	272.80	CUYD
0505	08150	STEEL REINFORCEMENT	50,860.00	LB
0506	08151	STEEL REINFORCEMENT-EPOXY COATED	71,167.00	LB
0507	08020	CRUSHED AGGREGATE SLOPE PROT	152.00	TON
0508	02231	STRUCTURE GRANULAR BACKFILL	187.00	CUYD
0509	02998	MASONRY COATING	632.00	SQYD
0510	08046	PILES-STEEL HP12X53	344.00	LF
0511	08094	PILE POINTS-12 IN	15.00	EACH
0512	08033	TEST PILES	63.00	LF
0513	08160	STRUCTURAL STEEL - (APPROXIMATELY 304,369 LBS.)	1.00	LS
0514	08170	SHEAR CONNECTORS - (APPROXIMATELY 5,442 LBS)	1.00	LS
0515	03299	ARMORED EDGE FOR CONCRETE	64.90	LF
0516	21420ED	DRILLED SHAFT-66 IN (COMMON)	78.00	LF
0517	20745ED	ROCK SOUNDINGS	78.00	LF
0518	20746ED	ROCK CORINGS	90.00	LF
0519	21421ED	DRILLED SHAFT-60 IN (SOLID ROCK)	60.00	LF
0520	21532ED	RAIL SYSTEM TYPE III	615.00	LF
0521	21342ED	FORM LINER	724.00	SQFT
0522	08434	CLEAN & PAINT STRUCTURAL STEEL	1.00	LS
0523	08100	CONCRETE-CLASS A	94.30	CUYD
0524	08150	STEEL REINFORCEMENT	8,659.00	LB
0525	08003	FOUNDATION PREPARATION	1.00	LS
0526	24596EN	GRANULAR BACKFILL	428.00	CUYD
0527	08100	CONCRETE-CLASS A	245.00	CUYD
0528	08150	STEEL REINFORCEMENT	23,500.00	LB
0529	08003	FOUNDATION PREPARATION	1.00	LS
0530	24596EN	GRANULAR BACKFILL	1,101.00	CUYD
0531	08100	CONCRETE-CLASS A	161.00	CUYD
0532	08150	STEEL REINFORCEMENT	14,600.00	LB
0533	08003	FOUNDATION PREPARATION	1.00	LS
0534	24596EN	GRANULAR BACKFILL	542.00	CUYD
0535	20603ED	SOIL NAIL WALL	3,372.00	SQFT
0536	08003	FOUNDATION PREPARATION	1.00	LS
0537	02572	QUALITY CONTROL	1.00	LS
0538	08100	CONCRETE-CLASS A	942.00	CUYD
0539	08150	STEEL REINFORCEMENT	127,000.00	LB
0540	08003	FOUNDATION PREPARATION	1.00	LS
0541	24596EN	GRANULAR BACKFILL	6,122.00	CUYD
0542	01065	STEEL ENCASEMENT PIPE-8 IN	256.00	LF
0543	01067	STEEL ENCASEMENT PIPE-10 IN	150.00	LF
0544	03537	BEND 11.25 DEG 4 IN	4.00	EACH
0545	03538	BEND 11.25 DEG 6 IN	2.00	EACH
0546	03544	BEND 22.50 DEG 4 IN	3.00	EACH
0547	03545	BEND 22.50 DEG 6 IN	3.00	EACH
0548	03553	BEND 45 DEG 4 IN	1.00	EACH
0549	03554	BEND 45 DEG 6 IN	1.00	EACH
0550	03559	BEND 90 DEG 4 IN	1.00	EACH

MATERIAL SUMMARY

Project Line No	Bid Code	DESCRIPTION	Quantity	Unit
0551	03560	BEND 90 DEG 6 IN	2.00	EACH
0552	20154ND	DRAIN ASSEMBLY - (4")	3.00	EACH
0553	20154ND	DRAIN ASSEMBLY - (6")	3.00	EACH
0554	21353ND	TIE-IN TO FORCE MAIN	4.00	EACH
0555	22082NN	AIR RELEASE VALVE ASSEMBLY - (4")	2.00	EACH
0556	22082NN	AIR RELEASE VALVE ASSEMBLY - (6")	2.00	EACH
0557	22960ED	BORE & JACK ENCASMENT PIPE-INSTALL - (8")	256.00	LF
0558	22984EN	PVC FORCE MAIN-6 IN	3,291.00	LF
0559	23528EC	PVC FORCE MAIN-4 IN-INSTALL	2,823.00	LF
0560	24149EC	BORE AND JACK PIPE-10 IN	150.00	LF
0561	24544EC	REMOVE - (6" FORCE MAIN)	180.00	LF
0562	06405	SBM ALUMINUM PANEL SIGNS	2,164.00	SQFT
0563	06406	SBM ALUM SHEET SIGNS .080 IN	428.00	SQFT
0564	06407	SBM ALUM SHEET SIGNS .125 IN	673.00	SQFT
0565	06410	STEEL POST TYPE 1	1,715.00	LF
0566	06441	GMSS GALV STEEL TYPE C	454.00	LB
0567	06451	REMOVE SIGN SUPPORT BEAM	5.00	EACH
0568	06490	CLASS A CONCRETE FOR SIGNS	6.00	CUYD
0569	06491	STEEL REINFORCEMENT FOR SIGNS	228.00	LB
0570	20418ED	REMOVE & RELOCATE SIGNS	3.00	EACH
0571	20419ND	ROADWAY CROSS SECTION	3.00	EACH
0572	20912ND	BARRIER WALL POST	10.00	EACH
0573	21373ND	REMOVE SIGN	13.00	EACH
0574	21596ND	GMSS TYPE D	16.00	EACH
0575	24631EC	BARCODE SIGN INVENTORY	122.00	EACH
0576	04793	CONDUIT-1 1/4 IN	80.00	LF
0577	04795	CONDUIT-2 IN	20.00	LF
0578	04811	ELECTRICAL JUNCTION BOX TYPE B	5.00	EACH
0579	04820	TRENCHING AND BACKFILLING	170.00	LF
0580	04829	PIEZOELECTRIC SENSOR	6.00	EACH
0581	04830	LOOP WIRE	7,278.00	LF
0582	04850	CABLE-NO. 14/1 PAIR	2,250.00	LF
0583	04895	LOOP SAW SLOT AND FILL	2,280.00	LF
0584	20359NN	GALVANIZED STEEL CABINET	2.00	EACH
0585	20360ES818	WOOD POST	4.00	EACH
0586	20391NS835	ELECTRICAL JUNCTION BOX TYPE A	2.00	EACH
0587	04700	POLE 30 FT MTG HT	49.00	EACH
0588	04701	POLE 40 FT MTG HT	44.00	EACH
0589	04720	BRACKET 4 FT	9.00	EACH
0590	04721	BRACKET 6 FT	53.00	EACH
0591	04723	BRACKET 10 FT	18.00	EACH
0592	04725	BRACKET 15 FT	14.00	EACH
0593	04740	POLE BASE	92.00	EACH
0594	04750	TRANSFORMER BASE	92.00	EACH
0595	04761	LIGHTING CONTROL EQUIPMENT	2.00	EACH
0596	04780	FUSED CONNECTOR KIT	190.00	EACH
0597	04797	CONDUIT-3 IN	1,380.00	LF
0598	04800	MARKER	2.00	EACH
0599	04820	TRENCHING AND BACKFILLING	17,030.00	LF
0600	04832	WIRE-NO. 12	13,435.00	LF

MATERIAL SUMMARY

Project Line No	Bid Code	DESCRIPTION	Quantity	Unit
0601	04833	WIRE-NO. 8	1,050.00	LF
0602	04860	CABLE-NO. 8/3C DUCTED	20,390.00	LF
0603	04940	REMOVE LIGHTING - (7-279)	1.00	LS
0604	20391NS835	ELECTRICAL JUNCTION BOX TYPE A	21.00	EACH
0605	21543EN	BORE AND JACK CONDUIT	1,245.00	LF
0606	24589ED	LED LUMINAIRE	94.00	EACH
0607	20000ES724	TREE - (EUROPEAN CRANBERRY VIBURNUM)	251.00	EACH
0608	20511NS724	PIN OAK	44.00	EACH
0609	21426NS724	NORWAY SPRUCE	42.00	EACH
0610	21429NS724	GREY OWL JUNIPER	506.00	EACH
0611	22000ED	WOOD PLANK FENCE	435.00	LF
0612	24394ES724	HAWTHORN - (WINTER KING)	133.00	EACH
0613	02568	MOBILIZATION	1.00	LS
0614	02569	DEMOBILIZATION	1.00	LS
0615	02742	TRAINEE PAYMENT REIMBURSEMENT - GROUP 2, 3 OR 4 OPERATOR	1,400.00	hour
0616	08100	CONCRETE-CLASS A	124.20	CUYD
0617	08104	CONCRETE-CLASS AA	50.30	CUYD
0618	08150	STEEL REINFORCEMENT	5,078.00	LB
0619	08151	STEEL REINFORCEMENT-EPOXY COATED	3,130.00	LB
0620	02998	MASONRY COATING	489.00	SQYD
0621	08434	CLEAN & PAINT STRUCTURAL STEEL	1.00	LS
0622	03298	EXPAN JOINT REPLACE 4 IN	161.00	LF
0623	03299	ARMORED EDGE FOR CONCRETE	161.00	LF
0624	08435	JACK & SUPPORT BRIDGE SPAN	1.00	LS
0625	02403	REMOVE CONCRETE MASONRY	31.00	CUYD
0626	21969NN	BEARING REPLACEMENT	22.00	EACH

CONTRACT ID: 141291

121GR14D091-NHPP & JL04

DE03400041491

NEW CIRCLE ROAD (KY 4) NEW CIRCLE ROAD REHAB AND WIDENING FROM VERSAILLES ROAD TO LEESTOWN BRIDGE WITH GRADE, DRAIN & SURFACE, A DISTANCE OF 2.4 MILES.

Project Line No	Bid Code	DESCRIPTION	Quantity	Unit
0001	00001	DGA BASE	91,608.00	TON
0002	00018	DRAINAGE BLANKET-TYPE II-ASPH	17,410.00	TON
0003	00020	TRAFFIC BOUND BASE	2,000.00	TON
0004	00100	ASPHALT SEAL AGGREGATE	287.00	TON
0005	00103	ASPHALT SEAL COAT	38.00	TON
0006	00190	LEVELING & WEDGING PG64-22	10,280.00	TON
0007	00212	CL2 ASPH BASE 1.00D PG64-22	69.00	TON
0008	00214	CL3 ASPH BASE 1.00D PG64-22	42,930.00	TON
0009	00216	CL3 ASPH BASE 1.00D PG76-22	4,755.00	TON
0010	00217	CL4 ASPH BASE 1.00D PG64-22	36,798.00	TON
0011	00219	CL4 ASPH BASE 1.00D PG76-22	16,346.00	TON
0012	00307	CL2 ASPH SURF 0.38B PG64-22	43.00	TON
0013	00336	CL3 ASPH SURF 0.38A PG76-22	1,611.00	TON

MATERIAL SUMMARY

Project Line No	Bid Code	DESCRIPTION	Quantity	Unit
0014	00339	CL3 ASPH SURF 0.38D PG64-22	4,061.00	TON
0015	00342	CL4 ASPH SURF 0.38A PG76-22	6,794.00	TON
0016	02069	JPC PAVEMENT-10 IN	1,740.00	SQYD
0017	02677	ASPHALT PAVE MILLING & TEXTURING	23,306.00	TON
0018	22861EN	HIGH STRENGTH GEOTEXTILE FABRIC	163,208.00	SQYD
0019	00021	DRAINAGE BLANKET-EMBANKMENT	6,200.00	CUYD
0020	00078	CRUSHED AGGREGATE SIZE NO 2	3,182.00	TON
0021	01310	REMOVE PIPE	390.00	LF
0022	01655	REMOVE JUNCTION BOX	1.00	EACH
0023	01691	FLUME INLET TYPE 2	1.00	EACH
0024	01718	REMOVE INLET	21.00	EACH
0025	01741	CORED HOLE DRAINAGE BOX CON-6 IN	39.00	EACH
0026	01787	REMOVE MANHOLE	1.00	EACH
0027	01825	ISLAND CURB AND GUTTER	242.00	LF
0028	01880	BARRIER HEADER CURB	32.00	LF
0029	01890	ISLAND HEADER CURB TYPE 1	1,078.00	LF
0030	01982	DELINEATOR FOR GUARDRAIL MONO DIRECTIONAL WHITE	195.00	EACH
0031	01984	DELINEATOR FOR BARRIER - WHITE	1,129.00	EACH
0032	01985	DELINEATOR FOR BARRIER - YELLOW	4,796.00	EACH
0033	02003	RELOCATE TEMP CONC BARRIER	47,200.00	LF
0034	02014	BARRICADE-TYPE III	28.00	EACH
0035	02091	REMOVE PAVEMENT	2,625.00	SQYD
0036	02159	TEMP DITCH	20,664.00	LF
0037	02160	CLEAN TEMP DITCH	61,992.00	LF
0038	02165	REMOVE PAVED DITCH	190.00	SQYD
0039	02200	ROADWAY EXCAVATION	157,008.00	CUYD
0040	02203	STRUCTURE EXCAV-UNCLASSIFIED	387.00	CUYD
0041	02223	GRANULAR EMBANKMENT	3,536.00	CUYD
0042	02242	WATER	1,957.00	MGAL
0043	02262	FENCE-WOVEN WIRE TYPE 1	2,694.00	LF
0044	02274	FENCE-6 FT CHAIN LINK	585.00	LF
0045	02351	GUARDRAIL-STEEL W BEAM-S FACE	9,456.00	LF
0046	02363	GUARDRAIL CONNECTOR TO BRIDGE END TY A	10.00	EACH
0047	02367	GUARDRAIL END TREATMENT TYPE 1	5.00	EACH
0048	02369	GUARDRAIL END TREATMENT TYPE 2A	10.00	EACH
0049	02381	REMOVE GUARDRAIL	9,122.00	LF
0050	02387	GUARDRAIL CONNECTOR TO BRIDGE END TY A-1	6.00	EACH
0051	02391	GUARDRAIL END TREATMENT TYPE 4A	7.00	EACH
0052	02429	RIGHT-OF-WAY MONUMENT TYPE 1	10.00	EACH
0053	02432	WITNESS POST	10.00	EACH
0054	02478	CAP INLET	1.00	SQYD
0055	02483	CHANNEL LINING CLASS II	3,056.00	TON
0056	02484	CHANNEL LINING CLASS III	2,315.00	TON
0057	02545	CLEARING AND GRUBBING - (APPROXIMATELY 83.3 ACRES, 7-113.01)	1.00	LS
0058	02555	CONCRETE-CLASS B	262.70	CUYD
0059	02562	TEMPORARY SIGNS	1,771.10	SQFT
0060	02567	DELINEATOR POSTS	40.00	EACH
0061	02585	EDGE KEY	64.00	LF
0062	02596	FABRIC-GEOTEXTILE TYPE I	500.00	SQYD

MATERIAL SUMMARY

Project Line No	Bid Code	DESCRIPTION	Quantity	Unit
0063	02599	FABRIC-GEOTEXTILE TYPE IV	46,500.00	SQYD
0064	02600	FABRIC GEOTEXTILE TY IV FOR PIPE	42,500.00	SQYD
0065	02625	REMOVE HEADWALL	18.00	EACH
0066	02650	MAINTAIN & CONTROL TRAFFIC - (7-113.01)	1.00	LS
0067	02671	PORTABLE CHANGEABLE MESSAGE SIGN	8.00	EACH
0068	02676	MOBILIZATION FOR MILL & TEXT - (7-113.01)	1.00	LS
0069	02690	SAFELOADING	136.20	CUYD
0070	02696	SHOULDER RUMBLE STRIPS-SAWED	48,700.00	LF
0071	02701	TEMP SILT FENCE	20,664.00	LF
0072	02703	SILT TRAP TYPE A	74.00	EACH
0073	02704	SILT TRAP TYPE B	74.00	EACH
0074	02705	SILT TRAP TYPE C	74.00	EACH
0075	02706	CLEAN SILT TRAP TYPE A	222.00	EACH
0076	02707	CLEAN SILT TRAP TYPE B	222.00	EACH
0077	02708	CLEAN SILT TRAP TYPE C	222.00	EACH
0078	02709	CLEAN TEMP SILT FENCE	61,992.00	LF
0079	02726	STAKING - (7-113.01)	1.00	LS
0080	02731	REMOVE STRUCTURE - (TWIN BRIDGES OVER ALEXANDRIA DRIVE, STA. 249+65.73)	1.00	LS
0081	02731	REMOVE STRUCTURE - (TWIN BRIDGES OVER RJ CORMAN RAILROAD, STA. 276+91.5)	1.00	LS
0082	02731	REMOVE STRUCTURE - (SINGLE BRIDGE OVER NEW CIRCLE ROAD, STA. 293+54.79)	1.00	LS
0083	02731	REMOVE STRUCTURE - (TWIN BRIDGES OVER RJ CORMAN RAILROAD, STA. 317+31.29)	1.00	LS
0084	03171	CONCRETE BARRIER WALL TYPE 9T	25,640.00	LF
0085	03260	CLEAN ROADWAY DRAINS	11.00	EACH
0086	04793	CONDUIT-1 1/4 IN - (REVISED: 11-7-14)	240.00	LF
0087	04795	CONDUIT-2 IN - (REVISED: 11-7-14)	60.00	LF
0088	04810	ELECTRICAL JUNCTION BOX	40.00	EACH
0089	04820	TRENCHING AND BACKFILLING - (REVISED: 11-7-14)	270.00	LF
0090	04829	PIEZOELECTRIC SENSOR - (REVISED: 11-7-14)	18.00	EACH
0091	04830	LOOP WIRE - (REVISED: 11-7-14)	8,850.00	LF
0092	04895	LOOP SAW SLOT AND FILL - (REVISED: 11-7-14)	1,695.00	LF
0093	05950	EROSION CONTROL BLANKET	7,825.00	SQYD
0094	05952	TEMP MULCH	403,293.00	SQYD
0095	05953	TEMP SEEDING AND PROTECTION	10,163.00	SQYD
0096	05963	INITIAL FERTILIZER	7.00	TON
0097	05964	20-10-10 FERTILIZER	11.00	TON
0098	05985	SEEDING AND PROTECTION	203,261.00	SQYD
0099	05989	SPECIAL SEEDING CROWN VETCH	53,600.00	SQYD
0100	05992	AGRICULTURAL LIMESTONE	126.00	TON
0101	06511	PAVE STRIPING-TEMP PAINT-6 IN	275,184.00	LF
0102	06514	PAVE STRIPING-PERM PAINT-4 IN	1,563.00	LF
0103	06514	PAVE STRIPING-PERM PAINT-4 IN	6,895.00	LF
0104	06515	PAVE STRIPING-PERM PAINT-6 IN	54,697.00	LF
0105	06515	PAVE STRIPING-PERM PAINT-6 IN	24,555.00	LF
0106	06517	PAVE STRIPING-PERM PAINT-12 IN	4,018.00	LF
0107	06568	PAVE MARKING-THERMO STOP BAR-24IN	71.00	LF
0108	06569	PAVE MARKING-THERMO CROSS-HATCH	2,647.00	SQFT
0109	06574	PAVE MARKING-THERMO CURV ARROW	7.00	EACH

MATERIAL SUMMARY

Project Line No	Bid Code	DESCRIPTION	Quantity	Unit
0110	06589	PAVEMENT MARKER TYPE V-MW	34.00	EACH
0111	06591	PAVEMENT MARKER TYPE V-BY	141.00	EACH
0112	06592	PAVEMENT MARKER TYPE V-B W/R	730.00	EACH
0113	06593	PAVEMENT MARKER TYPE V-B Y/R	124.00	EACH
0114	08100	CONCRETE-CLASS A	50.40	CUYD
0115	08901	CRASH CUSHION TY VI CLASS BT TL2	37.00	EACH
0116	08904	CRASH CUSHION TY VI CLASS C	2.00	EACH
0117	10020NS	FUEL ADJUSTMENT	294,073.00	DOLL
0118	10030NS	ASPHALT ADJUSTMENT	551,633.00	DOLL
0119	20099ES842	PAVE MARK TEMP PAINT STOP BAR	142.00	LF
0120	20100ES842	PAVE MARK TEMP PAINT LINE ARROW	14.00	EACH
0121	20209EP69	GRANULAR PILE CORE	328.00	CUYD
0122	20210EP69	COHESIVE PILE CORE	46.00	CUYD
0123	20359NN	GALVANIZED STEEL CABINET - (REVISED: 11-7-14)	6.00	EACH
0124	20360ES818	WOOD POST - (REVISED: 11-7-14)	12.00	EACH
0125	20391NS835	ELECTRICAL JUNCTION BOX TYPE A - (REVISED: 11-7-14)	6.00	EACH
0126	20394ES835	PVC CONDUIT-3 IN- IN MEDIAN BARRIER WALL	8,953.00	LF
0127	20411ED	LAW ENFORCEMENT OFFICER	200.00	HOURL
0128	20430ED	SAW CUT	47,444.00	LF
0129	20432ES112	REMOVE CRASH CUSHION	2.00	EACH
0130	22664EN	WATER BLASTING EXISTING STRIPE	105,272.00	LF
0131	23131ER701	PIPELINE VIDEO INSPECTION	7,777.00	LF
0132	23148EN	END ANCHORS	1.00	EACH
0133	23274EN11F	TURF REINFORCEMENT MAT 1	11,066.00	SQYD
0134	24255EC	REMOVE CABLE GUARDRAIL BARRIER SYSTEM	9,318.00	LF
0135	24654ED	SINGLE SLOPE MEDIAN BARRIER	9,899.00	LF
0136	24654ED	SINGLE SLOPE MEDIAN BARRIER	142.00	LF
0137	24654ED	SINGLE SLOPE MEDIAN BARRIER	147.00	LF
0138	00445	ENTRANCE PIPE-30 IN	48.00	LF
0139	00461	CULVERT PIPE-15 IN	11.00	LF
0140	00461	CULVERT PIPE-15 IN - (REINFORCED CONCRETE PIPE)	34.00	LF
0141	00462	CULVERT PIPE-18 IN	152.00	LF
0142	00464	CULVERT PIPE-24 IN	68.00	LF
0143	00464	CULVERT PIPE-24 IN - (REINFORCED CONCRETE PIPE)	24.00	LF
0144	00521	STORM SEWER PIPE-15 IN	3,223.00	LF
0145	00522	STORM SEWER PIPE-18 IN	2,507.00	LF
0146	00522	STORM SEWER PIPE-18 IN - (REINFORCED CONCRETE PIPE)	31.00	LF
0147	00524	STORM SEWER PIPE-24 IN	1,794.00	LF
0148	01000	PERFORATED PIPE-4 IN	12,265.00	LF
0149	01001	PERFORATED PIPE-6 IN	9,761.00	LF
0150	01010	NON-PERFORATED PIPE-4 IN	1,017.00	LF
0151	01011	NON-PERFORATED PIPE-6 IN	312.00	LF
0152	01015	INSPECT & CERTIFY EDGE DRAIN SYSTEM - (7-113.01)	1.00	LS
0153	01020	PERF PIPE HEADWALL TY 1-4 IN	50.00	EACH
0154	01024	PERF PIPE HEADWALL TY 2-4 IN	2.00	EACH
0155	01028	PERF PIPE HEADWALL TY 3-4 IN	11.00	EACH
0156	01032	PERF PIPE HEADWALL TY 4-4 IN	19.00	EACH
0157	01202	PIPE CULVERT HEADWALL-15 IN	4.00	EACH
0158	01204	PIPE CULVERT HEADWALL-18 IN	5.00	EACH

MATERIAL SUMMARY

Project Line No	Bid Code	DESCRIPTION	Quantity	Unit
0159	01208	PIPE CULVERT HEADWALL-24 IN	5.00	EACH
0160	01210	PIPE CULVERT HEADWALL-30 IN	1.00	EACH
0161	01432	SLOPED BOX OUTLET TYPE 1-15 IN	1.00	EACH
0162	01450	S & F BOX INLET-OUTLET-18 IN	2.00	EACH
0163	01451	S & F BOX INLET-OUTLET-24 IN	1.00	EACH
0164	01480	CURB BOX INLET TYPE B	5.00	EACH
0165	01496	DROP BOX INLET TYPE 3	5.00	EACH
0166	01517	DROP BOX INLET TYPE 5F	1.00	EACH
0167	01544	DROP BOX INLET TYPE 11	4.00	EACH
0168	01559	DROP BOX INLET TYPE 13G	2.00	EACH
0169	01568	DROP BOX INLET TYPE 13S	1.00	EACH
0170	01614	CONC MED BARR BOX INLET TY 14A2	3.00	EACH
0171	01615	CONC MED BARR BOX INLET TY 14B2	36.00	EACH
0172	01641	JUNCTION BOX-15 IN	2.00	EACH
0173	01642	JUNCTION BOX-18 IN	3.00	EACH
0174	01643	JUNCTION BOX-24 IN	3.00	EACH
0175	08100	CONCRETE-CLASS A	1.67	CUYD
0176	21799EN	BORE AND JACK PIPE-24 IN	357.00	LF
0177	21800EN	BORE AND JACK PIPE-30 IN	79.00	LF
0178	23126EN	BORE AND JACK PIPE-18 IN	501.00	LF
0179	24377EC	PREFAB BEND CONNECTION 25 DEG-15 IN	4.00	EACH
0180	24575ES610	HEADWALL - (DOUBLE 24 IN PIPE CULVERT)	1.00	EACH
0181	24634EC	BEND - (PREFAB CONNECTION 25 DEG-18 IN)	2.00	EACH
0182	24634EC	BEND - (PREFAB CONNECTION 25 DE-24 IN)	2.00	EACH
0183	08100	CONCRETE-CLASS A	273.60	CUYD
0184	08104	CONCRETE-CLASS AA	623.00	CUYD
0185	08150	STEEL REINFORCEMENT	59,187.00	LB
0186	08151	STEEL REINFORCEMENT-EPOXY COATED	166,178.00	LB
0187	08001	STRUCTURE EXCAVATION-COMMON	46.00	CUYD
0188	08020	CRUSHED AGGREGATE SLOPE PROT	829.00	TON
0189	02231	STRUCTURE GRANULAR BACKFILL	375.00	CUYD
0190	08046	PILES-STEEL HP12X53	505.00	LF
0191	08033	TEST PILES	155.00	LF
0192	08094	PILE POINTS-12 IN	30.00	EACH
0193	08671	PRECAST PC BOX BEAM SB33	2,090.70	LF
0194	21532ED	RAIL SYSTEM TYPE III	306.00	LF
0195	03299	ARMORED EDGE FOR CONCRETE	233.00	LF
0196	02998	MASONRY COATING	1,286.00	SQYD
0197	24654ED	SINGLE SLOPE MEDIAN BARRIER	153.00	LF
0198	08130	MECHANICAL REINF COUPLER #5	24.00	EACH
0199	08140	MECHANICAL REINF COUPLER #5 EPOXY COATED	12.00	EACH
0200	08133	MECHANICAL REINF COUPLER #8	32.00	EACH
0201	23583EC	DRILLED SHAFT-48 IN-COMMON	148.30	LF
0202	20637ED	DRILLED SHAFT-ROCK 48 IN	22.70	LF
0203	23584EC	DRILLED SHAFT-42 IN-ROCK	96.00	LF
0204	20392NS835	ELECTRICAL JUNCTION BOX TYPE C	4.00	EACH
0205	04797	CONDUIT-3 IN	539.00	LF
0206	20745ED	ROCK SOUNDINGS	172.20	LF
0207	20746ED	ROCK CORINGS	286.70	LF
0208	08100	CONCRETE-CLASS A	633.80	CUYD

MATERIAL SUMMARY

Project Line No	Bid Code	DESCRIPTION	Quantity	Unit
0209	08104	CONCRETE-CLASS AA	834.30	CUYD
0210	08150	STEEL REINFORCEMENT	126,832.00	LB
0211	08151	STEEL REINFORCEMENT-EPOXY COATED	243,815.00	LB
0212	08001	STRUCTURE EXCAVATION-COMMON	282.00	CUYD
0213	08020	CRUSHED AGGREGATE SLOPE PROT	984.00	TON
0214	02231	STRUCTURE GRANULAR BACKFILL	1,177.00	CUYD
0215	08051	PILES-STEEL HP14X89	1,122.00	LF
0216	08033	TEST PILES	245.00	LF
0217	08095	PILE POINTS-14 IN	37.00	EACH
0218	21532ED	RAIL SYSTEM TYPE III	359.00	LF
0219	03299	ARMORED EDGE FOR CONCRETE	297.30	LF
0220	02998	MASONRY COATING	1,167.00	SQYD
0221	02223	GRANULAR EMBANKMENT	30.00	CUYD
0222	08711	BRIDGE CHAIN LINK FENCE-6 FT	333.50	LF
0223	24654ED	SINGLE SLOPE MEDIAN BARRIER	173.40	LF
0224	08130	MECHANICAL REINF COUPLER #5	48.00	EACH
0225	08140	MECHANICAL REINF COUPLER #5 EPOXY COATED	12.00	EACH
0226	08133	MECHANICAL REINF COUPLER #8	32.00	EACH
0227	21777EN	DRILLED SHAFT COMMON-54 IN	253.60	LF
0228	20743ED	DRILLED SHAFT 54 IN-SOLID ROCK	27.40	LF
0229	20637ED	DRILLED SHAFT-ROCK 48 IN	112.00	LF
0230	23963EC	PPC I-BEAM TYPE HN36-49	2,365.90	LF
0231	20745ED	ROCK SOUNDINGS	292.50	LF
0232	20746ED	ROCK CORINGS	331.40	LF
0233	04797	CONDUIT-3 IN	600.00	LF
0234	20392NS835	ELECTRICAL JUNCTION BOX TYPE C	4.00	EACH
0235	08140	MECHANICAL REINF COUPLER #5 EPOXY COATED	16.00	EACH
0236	08130	MECHANICAL REINF COUPLER #5	40.00	EACH
0237	08100	CONCRETE-CLASS A	399.60	CUYD
0238	08104	CONCRETE-CLASS AA	827.80	CUYD
0239	08150	STEEL REINFORCEMENT	104,587.00	LB
0240	08151	STEEL REINFORCEMENT-EPOXY COATED	282,552.00	LB
0241	08001	STRUCTURE EXCAVATION-COMMON	58.40	CUYD
0242	23963EC	PPC I-BEAM TYPE HN36-49	2,292.30	LF
0243	08020	CRUSHED AGGREGATE SLOPE PROT	1,086.00	TON
0244	02231	STRUCTURE GRANULAR BACKFILL	564.00	CUYD
0245	02998	MASONRY COATING	940.00	SQYD
0246	08033	TEST PILES	240.00	LF
0247	03299	ARMORED EDGE FOR CONCRETE	267.30	LF
0248	08046	PILES-STEEL HP12X53	1,216.00	LF
0249	08094	PILE POINTS-12 IN	40.00	EACH
0250	21532ED	RAIL SYSTEM TYPE III	360.20	LF
0251	21777EN	DRILLED SHAFT COMMON-54 IN	125.20	LF
0252	20743ED	DRILLED SHAFT 54 IN-SOLID ROCK	14.00	LF
0253	20637ED	DRILLED SHAFT-ROCK 48 IN	98.00	LF
0254	20745ED	ROCK SOUNDINGS	203.00	LF
0255	20746ED	ROCK CORINGS	266.00	LF
0256	08039	PRE-DRILLING FOR PILES	760.00	LF
0257	24654ED	SINGLE SLOPE MEDIAN BARRIER	180.10	LF
0258	08140	MECHANICAL REINF COUPLER #5 EPOXY COATED	16.00	EACH

MATERIAL SUMMARY

Project Line No	Bid Code	DESCRIPTION	Quantity	Unit
0259	08130	MECHANICAL REINF COUPLER #5	40.00	EACH
0260	08141	MECHANICAL REINF COUPLER #6 EPOXY COATED	1,432.00	EACH
0261	08133	MECHANICAL REINF COUPLER #8	32.00	EACH
0262	24405EC	MECHANICAL REINF COUPLER-#8 EPOXY COATED	4.00	EACH
0263	04797	CONDUIT-3 IN	620.00	LF
0264	20392NS835	ELECTRICAL JUNCTION BOX TYPE C	4.00	EACH
0265	08711	BRIDGE CHAIN LINK FENCE-6 FT	348.00	LF
0266	08100	CONCRETE-CLASS A	581.90	CUYD
0267	08104	CONCRETE-CLASS AA	759.80	CUYD
0268	08150	STEEL REINFORCEMENT	130,405.00	LB
0269	08151	STEEL REINFORCEMENT-EPOXY COATED	195,643.00	LB
0270	08634	PRECAST PC I BEAM TYPE 4	2,516.20	LF
0271	08001	STRUCTURE EXCAVATION-COMMON	135.00	CUYD
0272	08002	STRUCTURE EXCAV-SOLID ROCK	591.00	CUYD
0273	08046	PILES-STEEL HP12X53	331.00	LF
0274	08033	TEST PILES	46.00	LF
0275	08094	PILE POINTS-12 IN	29.00	EACH
0276	08039	PRE-DRILLING FOR PILES	290.00	LF
0277	02231	STRUCTURE GRANULAR BACKFILL	505.00	CUYD
0278	08020	CRUSHED AGGREGATE SLOPE PROT	473.00	TON
0279	02998	MASONRY COATING	2,158.00	SQYD
0280	03299	ARMORED EDGE FOR CONCRETE	167.10	LF
0281	21532ED	RAIL SYSTEM TYPE III	639.80	LF
0282	04797	CONDUIT-3 IN	720.00	LF
0283	04810	ELECTRICAL JUNCTION BOX	2.00	EACH
0284	20392NS835	ELECTRICAL JUNCTION BOX TYPE C	4.00	EACH
0285	08100	CONCRETE-CLASS A	119.40	CUYD
0286	08150	STEEL REINFORCEMENT	11,014.00	LB
0287	08003	FOUNDATION PREPARATION	1.00	LS
0288	08002	STRUCTURE EXCAV-SOLID ROCK	43.00	CUYD
0289	02403	REMOVE CONCRETE MASONRY	30.20	CUYD
0290	23930EC	LIGHTWEIGHT CELLULAR CONCRETE FILL	1,909.00	CUYD
0291	08100	CONCRETE-CLASS A	229.20	CUYD
0292	08150	STEEL REINFORCEMENT	25,865.00	LB
0293	08003	FOUNDATION PREPARATION	1.00	LS
0294	08002	STRUCTURE EXCAV-SOLID ROCK	24.00	CUYD
0295	02403	REMOVE CONCRETE MASONRY	77.00	CUYD
0296	23930EC	LIGHTWEIGHT CELLULAR CONCRETE FILL	1,167.70	CUYD
0297	02203	STRUCTURE EXCAV-UNCLASSIFIED	3,549.00	CUYD
0298	02223	GRANULAR EMBANKMENT	760.00	CUYD
0299	08018	RETAINING WALL	7,275.00	SQFT
0300	08018	RETAINING WALL	30,660.00	SQFT
0301	21432NC	CONCRETE FORMLINER	25,900.00	SQFT
0302	08039	PRE-DRILLING FOR PILES	8,206.00	LF
0303	08033	TEST PILES	730.00	LF
0304	24718EC	PILES-STEEL W21 X 166	3,631.00	LF
0305	24719EC	PILES-STEEL W21 X 122	3,060.00	LF
0306	24720EC	PILES-STEEL W21 X 93	553.00	LF
0307	08170	SHEAR CONNECTORS - (APPROXIMATELY 7,196, 7-113.01)	1.00	LS

MATERIAL SUMMARY

Project Line No	Bid Code	DESCRIPTION	Quantity	Unit
0308	02231	STRUCTURE GRANULAR BACKFILL	314.00	CUYD
0309	02998	MASONRY COATING	459.00	SQYD
0310	02155	PAVED DITCH TYPE 1 MOD	774.00	SQYD
0311	02203	STRUCTURE EXCAV-UNCLASSIFIED	1,904.00	CUYD
0312	06400	GMSS GALV STEEL TYPE A	13,241.00	LB
0313	06401	FLEXIBLE DELINEATOR POST-M/W	70.00	EACH
0314	06404	FLEXIBLE DELINEATOR POST-M/Y	70.00	EACH
0315	06405	SBM ALUMINUM PANEL SIGNS	4,451.00	SQFT
0316	06406	SBM ALUM SHEET SIGNS .080 IN	70.00	SQFT
0317	06407	SBM ALUM SHEET SIGNS .125 IN	568.00	SQFT
0318	06410	STEEL POST TYPE 1	1,044.00	LF
0319	06412	STEEL POST MILE MARKERS	6.00	EACH
0320	06415	OSS GALV STEEL CANTILEVER	2.00	EACH
0321	06438	OSS ALUMINUM 80 FT TRUSS	1.00	EACH
0322	06441	GMSS GALV STEEL TYPE C	11,402.00	LB
0323	06449	REM OVERHEAD SIGN SUPPORT STR	1.00	EACH
0324	06450	REM OVERHEAD STRUC CONC BASE	1.00	EACH
0325	06451	REMOVE SIGN SUPPORT BEAM	40.00	EACH
0326	06490	CLASS A CONCRETE FOR SIGNS	76.00	CUYD
0327	06491	STEEL REINFORCEMENT FOR SIGNS	4,204.00	LB
0328	20418ED	REMOVE & RELOCATE SIGNS	3.00	EACH
0329	20419ND	ROADWAY CROSS SECTION	17.00	EACH
0330	21373ND	REMOVE SIGN	23.00	EACH
0331	21596ND	GMSS TYPE D	10.00	EACH
0332	24631EC	BARCODE SIGN INVENTORY	131.00	EACH
0333	24739EC	POLE 40 FT MTG HT W/12 IN ARM	40.00	EACH
0334	04710	POLE 80 FT MTG HT HIGH MAST	9.00	EACH
0335	04741	POLE BASE IN MEDIAN WALL	40.00	EACH
0336	04761	LIGHTING CONTROL EQUIPMENT	2.00	EACH
0337	04780	FUSED CONNECTOR KIT	80.00	EACH
0338	04797	CONDUIT-3 IN	1,053.00	LF
0339	04800	MARKER	11.00	EACH
0340	04820	TRENCHING AND BACKFILLING	5,600.00	LF
0341	04832	WIRE-NO. 12	5,400.00	LF
0342	04833	WIRE-NO. 8	6,750.00	LF
0343	04834	WIRE-NO. 6	21,000.00	LF
0344	04860	CABLE-NO. 8/3C DUCTED	6,000.00	LF
0345	04861	CABLE-NO. 6/3C DUCTED	1,200.00	LF
0346	04862	CABLE-NO. 4/3C DUCTED	2,500.00	LF
0347	04940	REMOVE LIGHTING - (7-113.01)	1.00	LS
0348	20391NS835	ELECTRICAL JUNCTION BOX TYPE A	11.00	EACH
0349	20392NS835	ELECTRICAL JUNCTION BOX TYPE C	2.00	EACH
0350	21543EN	BORE AND JACK CONDUIT	1,050.00	LF
0351	23161EN	POLE BASE-HIGH MAST	95.00	CUYD
0352	24589ED	LED LUMINAIRE	40.00	EACH
0353	20410ED	MAINTAIN LIGHTING - (7-113.01)	1.00	LS
0354	24749EC	HIGH MAST LED LUMINAIRE	48.00	EACH
0355	02568	MOBILIZATION	1.00	LS
0356	02569	DEMOBILIZATION	1.00	LS

MATERIAL SUMMARY

Project Line No	Bid Code	DESCRIPTION	Quantity	Unit
0357	02742	TRAINEE PAYMENT REIMBURSEMENT - GROUP 1 OPERATOR	1,600.00	HOUR
0358	02742	TRAINEE PAYMENT REIMBURSEMENT - CEMENT MASON	1,200.00	HOUR
0359	02742	TRAINEE PAYMENT REIMBURSEMENT - GROUP 2, 3 OR 4 OPERATOR	1,400.00	HOUR



**Sanitary Sewer
and
Pumping Station Manual**

**Lexington-Fayette Urban County Government
Lexington, Kentucky**

January 1, 2009

**SECTION 1.0
INTRODUCTION
TABLE OF CONTENTS**

	<u>Page</u>
1.1 General	1-1
1.2 Purpose	1-2
1.3 Structure of the Manual	1-3
1.4 Definitions	1-4
1.5 References	1-10

SECTION 2.0 DRAWING REQUIREMENTS

2.1	Sanitary Sewers	2-1
2.1.1	General	2-1
2.1.2	Geographical Features.....	2-1
2.1.3	Plan and Profile	2-1
2.1.4	Manholes	2-1
2.1.5	Lines	2-1
2.1.6	Elevations.....	2-1
2.1.7	Utilities and Easements	2-1
2.1.8	Miscellaneous	2-2
2.1.9	Plan Submitted	2-2
2.1.10	Checklists	2-2
2.2	Pumping Stations	2-3
2.2.1	General	2-3
2.2.2	Vicinity Map	2-3
2.2.3	Site Plan	2-3
2.2.4	Detailed Plan Sheets.....	2-3
2.2.5	Elevations.....	2-3
2.2.6	Miscellaneous Plan Details	2-4
2.2.7	Specifications and/or Drawings.....	2-4
2.2.8	Checklists	2-5

**SECTION 3.0
CONSTRUCTION PROCEDURES
TABLE OF CONTENTS**

	<u>Page</u>
3.1 Inspection and Construction Services	3-1
3.1.1 Construction Inspection Services.....	3-1
3.1.2 Construction Inspection Manual.....	3-1
3.1.3 Schedule	3-1
3.1.4 Changes	3-1
3.1.5 Shop Drawings	3-1
3.1.6 Utilities.....	3-1
3.2 Testing	3-3
3.2.1 Developer’s Responsibility.....	3-3
3.2.2 Required Testing for Sanitary Sewers.....	3-3
3.2.3 Required Testing for Pumping Stations	3-3
3.3 Operating Demonstration	3-4
3.3.1 Notification.....	3-4
3.3.2 Required Personnel for Demonstration	3-4
3.3.3 Operating Demonstration Requirements	3-4
3.4 Responsibilities to Avoid Damage to the System	3-5
3.4.1 Developer.....	3-5
3.4.2 Builder	3-5
3.4.3 Plumber	3-5
3.4.4 Utility Companies	3-6
3.5 Record Drawings	3-7
3.5.1 Format for Record Drawings	3-7
3.5.2 Requirements for Record Drawings	3-7
3.5.3 Precision for Record Drawings	3-8
3.6 System Acceptance by the LFUCG	3-9

**SECTION 4.0
FLOW DETERMINATION
TABLE OF CONTENTS**

	<u>Page</u>
4.1 Drainage Area	4-1
4.2 Flow Calculations	4-2
4.3 Example Calculation	4-4
 Tables	
4.1 Wastewater Flows.....	4-2
4.2 Peaking Factors... ..	4-3
4.3 Example Calculations.....	4-4

**SECTION 5.0
COMPUTER MODELING
TABLE OF CONTENTS**

	<u>Page</u>
5.1 Computer Modeling	5-1
5.1.1 Construction Inspection Services	5-1

**SECTION 6.0
SANITARY SEWERS
TABLE OF CONTENTS**

	<u>Page</u>
6.1 General	6-1
6.2 Collector Sewers	6-2
6.3 Trunk Sewers	6-3
6.4 Hydraulic Design Criteria	6-4
6.4.1 Manning’s Equation	6-4
6.4.2 Collector Sewer Criteria	6-4
6.4.3 Trunk Sewer Criteria	6-4
6.5 Manholes	6-5
6.5.1 Location	6-5
6.5.2 Spacing	6-5
6.5.3 Size	6-5
6.5.4 Elevations	6-5
6.5.5 Manhole Frames & Covers	6-5
6.5.6 Manhole Bench	6-5
6.5.7 Existing Brick Manholes	6-6
6.6 Pipeline Depth	6-7
6.7 Sewer System Integrity	6-8
6.8 Other Requirements	6-9
6.8.1 Service Laterals	6-9
6.8.2 Water Main Separation	6-9
6.8.3 Sewers in Fill Areas	6-9
6.9 Easements	6-10
6.9.1 General	6-10
6.9.2 Variances & Encroachments	6-10
6.9.3 Required Easement Widths	6-10

Tables

TABLE 6.1 – Minimum Allowable Slopes	6-4
TABLE 6.1 – Easement Widths	6-11

**SECTION 7.0
PUMPING STATIONS
TABLE OF CONTENTS**

	<u>Page</u>
7.1 Administrative Procedures	7-1
7.1.1 General.....	7-1
7.1.2 Design of Pumping Station.....	7-2
7.1.3 Design Approval Process.....	7-2
7.2 Classes of Pumping Stations	7-3
7.2.1 Class A and B Pumping Stations.....	7-3
7.2.2 Class C and D Pumping Stations.....	7-3
7.2.3 Pumping Stations Permanent.....	7-4
7.2.4 Pumping Station Class Requirements.....	7-4
7.3 Hydraulic Design Criteria	7-5
7.3.1 Wetwell Sizing.....	7-5
7.3.2 Example.....	7-5
7.3.3 Force Main Sizing.....	7-6
7.3.4 Factors Affecting Pump Selection.....	7-7
7.4 Class A and B Pumping Station Details	7-8
7.4.1 Class A and B Building.....	7-8
7.4.2 Class A and B Bar Screen.....	7-8
7.4.3 Class A and B Flow Measurement.....	7-8
7.4.4 Class A and B Odor Control.....	7-8
7.4.5 Class A and B Emergency Power.....	7-8
7.4.6 Class A and B Telemetry System.....	7-9
7.4.7 Class A and B Wetwells.....	7-10
7.4.8 Class A and B Pumps.....	7-11
7.4.9 Class A and B Fencing.....	7-11
7.4.10 Class A and B Landscaping.....	7-11
7.4.11 Class A and B Access Roads & Turnarounds.....	7-11
7.4.12 Class A and B Buffer Zones.....	7-11
7.5 Class C and D Pumping Station Details	7-12
7.5.1 Class C and D Building.....	7-12
7.5.2 Class C and D Bar Screen.....	7-12
7.5.3 Class C and D Flow Measurement.....	7-12
7.5.4 Class C and D Odor Control.....	7-12
7.5.5 Class C and D Emergency Power.....	7-12
7.5.6 Class C and D Telemetry.....	7-12
7.5.7 Class C and D Wetwells.....	7-13

**SECTION 7.0
PUMPING STATIONS
TABLE OF CONTENTS
(Continued)**

7.5.8	Class C and D Pumps	7-13
7.5.9	Class C and D Control Enclosure.....	7-13
7.5.10	Class C and D Fencing.....	7-13
7.5.11	Class C and D Landscaping.....	7-13
7.5.12	Class C and D Access Roads.....	7-14
7.6	Force Main Details.....	7-15
7.6.1	Force Main Blocking	7-15
7.6.2	Force Main Air Releases.....	7-15
7.6.3	Force Main Markers	7-15
7.6.4	Force Main Discharge Point	7-15
7.6.5	Force Main Materials	7-15
7.6.6	Force Main Isolation Valves.....	7-16
7.7	Use of Approved Equipment.....	7-17
Tables		
7.1	Requirements for Pumping Stations.....	7-4
7.2	Force Main Sizing	7-6
7.3	Class A & B Telemetry Requirements.....	7-9
7.4	Class C & D Telemetry Requirements.....	7-13

TABLE OF CONTENTS

APPENDICES

- Appendix A – Checklists
- Appendix B – Drawings
- Appendix C - Specifications

CHAPTER 1 INTRODUCTION

1.1 General

The Sanitary Sewer and Pumping Station Manual is one of seven manuals developed by the Lexington-Fayette Urban County Government (LFUCG) for the design and construction of infrastructure. The specific subjects of these manuals are:

- Procedures Manual for Infrastructure Development
- Stormwater
- Roadway
- Sanitary Sewer and Pumping Station
- Structures
- Geotechnical
- Construction Inspection

1.2 Purpose

The purpose of this manual is to provide information regarding design and construction requirements for sanitary sewers, pumping stations, and force mains in Fayette County. The goal is to provide uniform design and construction standards. The end result will be public infrastructure that is cost effective and maintainable by the LFUCG in the long term.

1.3 Structure of the Manual

The manual is composed of the following sections:

Section 2 - Drawing Requirements

Outlines the requirements for plans submitted to the LFUCG for sanitary sewers, pumping stations, and force mains.

Section 3 - Construction Procedures

Defines roles and responsibilities during the construction process and lists the construction inspection testing required.

Section 4 - Flow Determination

Provides the information necessary to calculate flows for sanitary sewers, pump stations, and force mains.

Section 5 - Computer Modeling

Discusses the status of computer modeling.

Section 6 - Sanitary Sewers

Provides the information necessary to properly design sanitary sewers and defines the requirements for utility easements.

Section 7 - Pumping Stations

Defines the classes of pumping stations and their requirements and the hydraulic design criteria to design pumping stations and force mains.

1.4 Definitions

AASHTO - An abbreviation for American Association of State Highway and Transportation Officials.

AWWA - An abbreviation for American Water Works Association.

Air Release Valve - Valve installed at high points to allow gases to escape.

ASTM - An abbreviation for American Society for Testing and Materials.

Backfill - The refilling of an excavation after a structure has been placed therein or the material placed in an excavation in the process of backfilling. In sewer construction, backfill refers to the material placed in the trench from the top of the pipe encasement or cap up to the ground or subgrade level.

Builder - The person(s) or firm who constructs a residential house, apartment, or commercial building(s) on part or all of a development.

Carrier Pipe - Sanitary or storm sewer piping slipped inside the installed casing pipe.

Casing Pipe - Steel pipe with continuous circumferential butt-welded joints, jacked into position during the boring operation.

Castings - Metallic objects (normally cast iron) formed of molten metal in a mold. Examples are manhole lids, manhole rims, catch basin grates, and frames, etc.

Check Valve - Valve that prevents fluid, such as sewage, from flowing backwards.

Cleanout - An upturned sewer pipe, generally placed at the end of the sewer, for providing means for inserting cleaning tools, for flushing, or for inserting an inspection light into the sewer.

Clearing - The cutting and removal of all trees, logs, and brush to about 1 foot above the ground surface.

Compaction - The act of compressing a given volume of material into a smaller volume by rolling, tamping, or wetting. In earthwork construction, subgrade preparation, and in paving, compaction is needed to increase the density, strength, and stability of the soil or bituminous concrete and decrease its permeability.

Construction Inspector - The individual who will provide the day-to-day, full-time inspection of a project under the direction of the Engineer.

Contractor - The person(s) or firm hired by the Developer or LFUCG to construct the infrastructure.

Control Panel - A panel with electrical controls for pump operations that generally includes an electrical pump operations display.

Cradle - Refers to bedding and haunching materials being laid upward from the trench bottom to the springline of the pipe.

Developer - The person(s) or firm that owns the land which is being developed and who is responsible for the construction of the infrastructure.

Development - The land which is being converted to a particular use and for which the infrastructure is being constructed.

DI - An abbreviation for Ductile Iron (piping).

Duplex - A pumping station containing two pumps.

Encasement - Class A concrete used to enclose a sewer in a trench. Encasement shall extend at least 6 inches all the way around the outside of the exterior wall of the pipe being encased.

Enclosure - The cabinet or specially designed box in which electrical controls and apparatus are housed. It is required to protect persons from live electrical parts and limit access to authorized personnel. It also provides mechanical and environmental protection.

Engineer - The engineering firm responsible for the design of the sanitary sewer, pumping station, and force main.

Exfiltration - The exit of sewage through faulty joints or cracks in pipes or manholes.

Force Main - A pipe under internal pressure created by being on the discharge side of a pumping station.

Gate Valve - Manual, screw-type, pipe valves within the discharge piping that isolate one or both of the discharge pipes from the force main during maintenance.

GPM (gpm) - An abbreviation for gallons per minute.

Grout - A fluid mixture of cement, sand, and water that can be poured or pumped easily.

Guide Rails - Steel tracks that align the boring equipment to the correct pipe direction and grade within the boring pit. Also includes the steel rails that align the submersible pumps to the discharge pipes.

Guide Rail System - A device that allows the submersible pump-motor unit to be installed in or removed from the wet well, without disconnecting any piping and without anyone having to enter the wet well.

Grubbing - The removal of all stumps and roots after the clearing operation.

Haunches - Pipe exterior below the springline to the outside bottom where crushed stone shall be hand placed and consolidated to provide uniform side and bottom support.

HDPE - An abbreviation for High Density Polyethylene (piping).

Home - Refers to condition that occurs when spigot or tongue end of pipe has been properly inserted into the bell or groove end. On PVC pipes, a reference mark is provided on the spigot end to indicate when the section of pipe has been pushed "home."

Infiltration - The entrance of groundwater into a sewer system through faulty joints or cracks in the pipes or manholes.

Invert - The lower portion of a sewer or structure; the portion that is below the springline and is concave upward. Also, the lowest point on the inside surface of a sewer is referred to as the invert, particularly in reference to the elevation or slope of the sewer.

Lag Pump - A succeeding or backup pump in a pump system. Control systems usually alternate pump operations between the lead and lag pumps.

Lateral - Sewer line from a residential unit to the collector sewer, consisting of two (2) components, the house lateral from the residential unit to the easement and/or R/W, and the sewer lateral from the easement and/or R/W to the collector sewer.

Lead Pump - The first pump to start in a pump cycle.

LFUCG - An abbreviation for the Lexington-Fayette Urban County Government.

Mandrel - A device used to check installed flexible pipe for excessive deflection (greater than 5%). A mandrel is specifically sized for the diameter of pipe to be tested. As the mandrel is pulled through the pipe, excessive deflection in the pipe will prevent its passage.

Manhole - A sewer appurtenance installed to provide: 1) access to sewers for inspection and maintenance; and 2) for changes in sewer direction, elevation, and grade.

Markers - Concrete or steel posts that identify force main alignments. Also includes metallic tape.

Maximum Dry Density - The maximum density obtained in a Proctor moisture-density test using a specific compactive effort and method of compaction specified by ASTM D 698 or ASTM D 1557.

Mercury Float Switches - Electrical mercury switches mounted in watertight, polyurethane-coated, steel shell, tilt bulbs suspended from the top slab of the wet well/pit that start/stop the pumps. Usually four switches control the pump operations.

Non-Submersible Pumps - Wastewater pumps used in dry pump chambers designed to operate in open air.

Optimum Moisture Content - The moisture content corresponding to the maximum dry density in a Proctor moisture-density test.

PVC - An abbreviation for Polyvinyl Chloride (piping).

Percent Compaction - The ratio, expressed as a percentage of: 1) dry unit weight of a soil as established in a job site embankment or backfill; 2) maximum unit weight obtained in a laboratory compaction test.

Plumber - The person(s) or firm that subcontracts with a builder to install the plumbing system in a building or house, including the lateral.

Precast - That which is formed in a mold or formed and distributed by the manufacturer as a complete unit.

Proctor Test - A laboratory compacting procedure whereby a soil at a known water content is placed in a specified manner into a mold of given dimensions, subjected to a compactive effort of controlled magnitude, and the resulting unit weight determined. The procedure is repeated for various water contents sufficient to establish a relation between water content and unit weight.

RCP - An abbreviation for Reinforced Concrete Pipe.

Record Drawings - Engineering plans that have been revised to reflect all changes to the plans that occurred during construction.

RPM - An abbreviation for Revolutions per Minute

Sanitary Sewer - A sewer that carries liquid and waterborne wastes from residences, commercial buildings, industrial plants, and institutions, together with minor quantities of ground, storm, and surface waters that are not admitted intentionally.

SDR - Abbreviation for the Standard Dimension Ratio expressed as the outside diameter of the pipe divided by the pipe wall thickness.

Sealing Flange - The connection between the pump discharge and force main when used with guide rail systems.

Service Pole - Utility pole providing electrical service, usually equipped with electric meter and telemetry enclosure.

Sewage - Largely the water supply of the common community after it has been fouled by various uses.

Sewer - A pipe or enclosed channel that carries wastewater or drainage water.

Slope - The gradient in feet per foot or expressed as percent.

Springline - The line on the outermost points on the side of a sewer. On a circular sewer, it would be the line on the points at half the diameter above the invert.

Station - A distance of 100 feet, measured along a centerline or baseline and designated by a stake bearing its number.

Storm Sewer - A sewer that carries storm water and surface water, street wash and other wash waters, or drainage, but excludes domestic wastewater and industrial wastes. Also called storm drain.

Stripping - The removal of topsoil or other material unsuitable for use in compacted earth fill, beneath foundations, or pavements.

Structural Fill - Selected fill material placed, compacted, and inspected according to specific density and moisture requirements.

Submersible Pumps - Submersible wastewater pumps are vertical, close-coupled, extra-heavy-duty pump and motor units that are designed to operate beneath the liquid they are pumping. They are non-clogging, usually having a 3-inch or larger discharge, and are also called submersible sewage pumps.

Support Bracket - Metal mounts that secure the discharge pipe(s) to the internal wall of the wet well.

TDH - An abbreviation for Total Dynamic Head.

Telemetry - The transmitting of alarm and control signals from remote pump station controls to a central monitoring location.

Topsoil - Soil at or below the ground surface, usually high in organic content and unsuitable for structural fill applications.

Trench - Usually a long, narrow, near vertical-sided cut in rock or soil such as is made for utility lines.

Trench Width - A specified minimum or maximum horizontal trench dimension which shall be maintained from below the pipe to at least one foot above the top of pipe.

TV Survey - Inspection method for PVC sanitary sewers where a video camera and skid assembly is pulled through a pipe section.

Valve Vault - Precast or cast-in-place concrete structure housing gate valves, check valves, and air release valves.

Volute - The casing of a centrifugal pump made in the form of a spiral or volute as an aid to the partial conversion of the velocity energy into pressure head as the water leaves the impeller.

Wet Well - An underground concrete storage tank for the temporary storage of sewer influent and containment of submersible pumps, piping, and float bulb switches.

1.5 References

Design Manual, Louisville and Jefferson County Metropolitan Sewer District (MSD), Revised Edition, 1995.

Lexington/Fayette Urban County Sanitary Sewer Pumping Stations; General Requirements for Administration, Design and Construction, July 1992.

Recommended Standards for Wastewater Facilities, Ten States Standards, 1990.

Design of Wastewater and Stormwater Pumping Stations, Manual of Practice ED-4, Water Environment Federation, 1993.

CHAPTER 2 DRAWING REQUIREMENTS

2.1 Sanitary Sewers

2.1.1 General

Plans submitted to the LFUCG shall include all information necessary to evaluate the proposed design. A comprehensive plan of existing and proposed sewers shall be included for projects involving new sewer systems and/or additions to existing systems.

2.1.2 Geographical Features

All geographical features shall be shown. Topography and elevations of all existing and proposed streets, streams, or water surfaces shall be shown. Contour lines shall be at 2-foot intervals.

The direction of flow in all streams, high and low water elevations of all water surfaces near the sewers shall be shown. 100-year flood elevations shall be shown. The boundaries of the proposed development shall be shown.

2.1.3 Plan and Profile

Plans shall show the location size and direction of all proposed and existing sewers. Plan sheets and profile sheets shall be at a scale no smaller than 1 inch = 50 feet horizontal, and 1 inch = 5 feet vertical.

2.1.4 Manholes

Manhole numbers, manhole stations, deflection angles, and coordinates of manholes shall be shown on the plans.

2.1.5 Lines

The distance between manholes, pipe size, and slope shall be shown on each line segment.

2.1.6 Elevations

Elevations shall conform to the LFUCG datum and be shown at all manhole inverts, tops of manhole and other places as necessary to define the design intent.

2.1.7 Utilities and Easements

The plans shall show all existing utilities and structures, both above and below ground which might interfere with the proposed construction. Easements and locations of all proposed utilities shall be shown on the plans. Refer to 6.9 Easements for additional information.

2.1.8 *Miscellaneous*

Legends, vicinity map, north arrows, and any other information required for a complete set of sanitary sewer drawings shall be submitted.

2.1.9 *Plans Submitted*

After submittal to and approval by the State Division of Water one (1) set of the state-approved plans shall be returned to the LFUCG. Record Drawings shall be submitted in accordance with that section of this manual.

2.1.10 *Checklists*

Checklists to be submitted with the plans are included at the end of Section 2.

2.2 Pumping Stations

2.2.1 General

The LFUCG has developed standard Class C and D pumping station drawings on AutoCAD Release 14 to provide guidelines for the preparation of design plans. These drawings are intended to show the requirements for Class C and D pumping stations and the type of information that is required on the plans. These drawings are not intended to be used in a “cook book” fashion or to minimize the role and/or the responsibility of the Engineer. The Engineer has the ultimate responsibility for the design.

The pumping station shall be designed to meet or exceed the requirements of all Federal, State and Local laws and ordinances, and applicable design standards recommended by the Ten State Standards.

2.2.2 Vicinity Map

Show existing pump stations, force mains, and trunk sewers within a 1-mile radius of the proposed station. Also, indicate the size and minimum grade of the gravity sewer receiving the discharge of the proposed station.

2.2.3 Site Plan

The site plan shall show the following:

- Topographic features and contours
- Location of station relative to existing features and survey base lines as needed
- Existing and proposed utilities
- Existing and proposed property lines and easements
- Bench marks (must tie into LFUCG datum)
- Known high water and/or projected maximum flood elevations (100 year frequency)
- Access road, parking, turn-around, regrade and drainage
- Subsurface information, as appropriate
- Fencing
- Landscaping when required

2.2.4 Detailed Plan Sheets

Provide sufficient plan, section and elevation views to indicate the intent of what is to be furnished.

2.2.5 Elevations

Specific elevations shall be indicated for the following items:

- Vent (above high water and regrade)

- Overflow invert
- Sewer influent invert
- Top of wet well top slab (above regrade)
- Pump start
- Pump stop
- Second pump start
- High water level alarm
- Top of foundation slab
- Regrade
- Top of valve pit

2.2.6 *Miscellaneous Plan Details*

The following details shall be included on the drawings:

- Manholes and castings
- Pump station and valve covers
- Locking device for wet well and pump station covers shall be hasp and keeper for padlock. Padlock to be furnished by Urban County Government
- Piping connections
- Electrical details, including service pole with weather-tight, lockable, disconnect switches and control boxes
- Pump station and wet well protection - fenced as directed by Division of Water Quality

2.2.7 *Specifications and/or Drawings*

The following items shall be shown as details on the drawings and/or included in the specifications:

- Lights - Outside on service pole
- Fence - Chain Link, Farm type or other as necessary to match surrounding area
- Paving - Drives and Turnarounds
- Pump Control Panels - For lead/lag duplex pump operation
- Telemetry System - To operate with existing telemetry system
- Spare Parts - Volute gaskets, mechanical seal, impeller, fuses for control power, pump motor if applicable and main disconnect, and spare starter
- O&M Manuals - Require three copies of operation and maintenance manuals and manufacturer's parts list, for all equipment, be furnished to the Division of Water Quality prior to final acceptance
- Painting - Paint piping and appurtenances in the valve vaults and wet wells with coal tar epoxy
- Valves - Valves on each non-submersible pump suction pipe and discharge pipe and check valves on each discharge pipe for both submersible and nonsubmersible systems.

- Pipe - Suction pipe shall not be less than 6" diameter and discharge pipe shall not be less than 4" diameter

2.2.8 Checklists

Checklists to be submitted with the plans are included at the end of Section 2.

Sanitary Sewer Plans Checklist

- _____ 1. Plans are stamped by a Licensed Professional Engineer in the Commonwealth of Kentucky
- _____ 2. Flow determinations consistent with Section 4 have been made
- _____ 3. The receiving system has the capacity for the proposed flows
- _____ 4. All geographical features shown
- _____ 5. Topography and elevations of all existing features shown
- _____ 6. Topography and elevations of all proposed features shown
- _____ 7. Contours at 2 ft. Intervals
- _____ 8. Direction of flow in streams indicated
- _____ 9. 100-year flood elevation shown
- _____ 10. Location, size and direction of existing sewers shown
- _____ 11. Location, size and direction of proposed sewers shown
- _____ 12. Plan and profile sheets at 1" = 50 ft. horizontal and 1" = 5 ft. vertical
- _____ 13. Manhole numbers shown
- _____ 14. Manhole stations shown
- _____ 15. Deflection angles shown
- _____ 16. Coordinates of manholes shown
- _____ 17. Distance between manholes, pipe size, and slope shown on each line segment
- _____ 18. Elevations confirm to LFUCG datum
- _____ 19. Elevations shown at manhole inverts and rims
- _____ 20. All existing utilities and structures, above and below ground shown
- _____ 21. All easements indicated on plans
- _____ 22. All utilities are shown in the easements
- _____ 23. Easement widths are consistent with Section 6.9.3 Required Easement Widths
- _____ 24. Conflicts (main lines or laterals) with the storm sewer or other utilities
- _____ 25. Laterals shown for each lot
- _____ 26. 6" laterals shown where required
- _____ 27. No collector or trunk sewers are located in storm retention basins or their embankments, or the 10-year flood plain
- _____ 28. Hydraulic design criteria of Section 6.4 has been followed including velocities and slopes
- _____ 29. Manhole design and location is consistent with section 6.5
- _____ 30. Pipeline depth is consistent with Section 6.6
- _____ 31. Sewer system integrity requirements of Section 6.7 are met
- _____ 32. Legends, vicinity map, north arrows etc. shown

Pumping Station Plans Checklist

- _____ 1. Plans are stamped by a Licensed Professional Engineer in the Commonwealth of Kentucky
- _____ 2. Flow determinations consistent with Section 4 have been made
- _____ 3. Class of the pumping station is indicated
- _____ 4. Design criteria for the class of pumping station are followed
- _____ 5. Wet well sizing is consistent with Section 7.3.1
- _____ 6. Force main sizing is consistent with 7.3.3
- _____ 7. Other factors such as those listed in 7.3.4 have been considered
- _____ 8. Pump rate (gpm) and total dynamic head (TDH) are given
- _____ 9. All geographical features shown
- _____ 10. Subsurface information, as appropriate, is provided
- _____ 11. Topography and elevations of all existing features shown
- _____ 12. Topography and elevations of all proposed features shown
- _____ 13. Contours at 2 ft. Intervals
- _____ 14. Direction of flow in streams indicated
- _____ 15. 100-year flood elevation shown
- _____ 16. Existing pumping stations, force mains, and trunk sewers within 1 mile radius of the proposed pumping station shown
- _____ 17. Size, minimum grade of sewer at discharge point of force main is given
- _____ 18. Location, size and direction of existing sewers shown
- _____ 19. Location, size and direction of proposed sewers shown
- _____ 20. Location, size, and direction of existing force mains shown
- _____ 21. Location, size, and direction of proposed force main shown
- _____ 22. Manhole numbers shown
- _____ 23. Manhole stations shown
- _____ 24. Deflection angles shown
- _____ 25. Coordinates of manholes and pumping station shown
- _____ 26. Distance between manholes, pipe size, and slope shown on each line segment
- _____ 27. Bench marks are shown
- _____ 28. Elevations confirm to LFUCG datum
- _____ 29. Elevations shown at manhole inverts and rims
- _____ 30. All existing utilities and structures, above and below ground shown
- _____ 31. Property lines for the proposed pumping station property are indicated
- _____ 32. All easements indicated on plans
- _____ 33. All utilities shown in the easements
- _____ 34. Legends, vicinity map, north arrows etc. shown
- _____ 35. Access roads, parking, turnarounds are shown
- _____ 36. Regrade and drainage are shown
- _____ 37. Fencing of the site is shown
- _____ 38. Landscaping is shown
- _____ 39. Plan and section views sufficient to indicate what is to be built and what equipment is to be furnished
- _____ 40. All equipment to be furnished is on the approved equipment list of the LFUCG
- _____ 41. Elevations given for all structural and operational points given
- _____ 42. Painting is defined and/or specified
- _____ 43. Appropriate details for all misc. items
- _____ 44. Telemetry system consistent with 7.4.6 or 7.5.6 to operate with existing LFUCG system

CHAPTER 3 CONSTRUCTION PROCEDURES

3.1 Inspection and Construction Services

3.1.1 Construction Inspection Services

In accordance with the requirements of the LFUCG Procedures Manual for Infrastructure Development, construction inspection services shall be provided by the same Engineer that prepared the Improvement Plans.

3.1.2 Construction Inspection Manual

Details of the Construction Inspector duties and responsibilities are defined in the LFUCG Construction Inspection Manual. Information provided in this manual is intended to supplement and add to the information provided in the Construction Inspection Manual and not to replace or delete any requirements of that manual.

3.1.3 Schedule

The Engineer shall keep the Division of Engineering and the Division of Water Quality informed as to the status of the project. The Engineer shall submit copies of the daily field reports to the Division of Engineering. The Engineer shall notify the Division of Engineering and the Division of Water Quality prior to conducting required tests.

3.1.4 Changes

The Division of Engineering and the Division of Water Quality shall be notified of significant changes to the plans and specifications. In addition, the Kentucky Division of Water shall approve such changes.

3.1.5 Shop Drawings

The Engineer shall ascertain that shop drawings are submitted and approved prior to construction or shipment of equipment.

Three copies of approved shop drawings and operating and maintenance instructions for each piece of equipment shall be submitted to the Division of Water Quality, one (1) copy before installation of the equipment, and two (2) copies upon completion of the project. (Refer to Section 3.3 Operating Demonstration hereinafter.) Items to be included are pumps, motors, drive units, compressors, valves, control equipment, electrical panels, sump pumps, fans and all other equipment installed. One laminated copy of the electrical schematic shall be installed in the station's control panel.

3.1.6 Utilities

All utilities required for the construction and initial operation of a pumping station shall be furnished and paid for by the Developer, unless specifically agreed to otherwise in writing by the LFUCG.

“Initial operation” for this purpose shall mean all operation until such time as the LFUCG officially assumes operation of the pump station.

All temporary utility services shall be the responsibility of the Developer.

Obtaining permanent utility services shall also be the responsibility of the Developer. However, the LFUCG shall provide such assistance as necessary to satisfy the utility company that the LFUCG will assume payment of utility bills after completion of initial operations.

3.2 Testing

3.2.1 Developer's Responsibility

All testing required for the acceptance of sewer systems and pumping stations by the LFUCG are the responsibility of the Engineer. The Division of Engineering and the Division of Water Quality shall be notified of all testing 72 hours in advance.

3.2.2 Required Testing for Sanitary Sewers

Testing shall be done in accordance with the Construction Inspection Manual. Required tests for sanitary sewers include:

- Manhole Vacuum Test
- Low-Pressure Air Test
- Deflection Test
- Infiltration/Exfiltration Test (for concrete pipe only)
- TV Survey

The Deflection test shall be conducted after the trench has been backfilled for a minimum of 30 days.

The TV Survey shall be used to confirm the locations of tees for house laterals and may be used to evaluate workmanship and materials.

3.2.3 Required Testing for Pumping Stations

Testing shall be done in accordance with the Construction Inspection Manual. Required tests for pumping stations and force mains include:

- Hydrostatic Pressure Test
- Wet well Vacuum Test
- Drawdown and Pump Test
- Operating Demonstration

3.3 Operating Demonstration

3.3.1 Notification

When the work has been completed and all systems have been tested and are operating in accordance with the specified and/or approved plans and specifications, an operating demonstration shall be held by the Engineer. The following shall be notified in writing at least 72 hours in advance of the operating demonstration:

- Division of Water Quality
- Division of Engineering

3.3.2 Required Personnel for Demonstration

The following persons shall be present for the operating demonstration:

- Developer or his representative
- Engineer
- Contractor
- Equipment supplier service representative
- Representative of the Division of Water Quality and the Division of Engineering

3.3.3 Operating Demonstration Requirements

The operating demonstration shall consist of the following:

- Operating demonstration of all equipment
- Discussion of operation and maintenance procedures, with emphasis on unusual equipment
- Delivery of two additional copies of instruction books and operation and maintenance manuals to the Division of Sanitary Sewer's Representative
- Inventory and receipt for all spare parts furnished with the station
- Correction of all deficiencies noted during the operating demonstration
- Copies of drawdown and pump tests
- Certification by the Engineer of force main pressure test

3.4 Responsibilities to Avoid Damage to the System

3.4.1 Developer

It is the Developer's responsibility to turn over to the LFUCG a complete, undamaged, operable sanitary sewer system, including pumping stations, after all utilities are installed. It is recognized that the Developer does not have total control over other Utility Companies installing other utilities such as water, electric, gas, cable, and telephone, but the Developer shall take the lead role in coordinating and checking the activities of the Utilities and in holding them responsible for any damage to the sanitary sewer system. The Construction Inspector shall be utilized to the extent necessary to protect the sanitary sewer system while other utilities are being installed.

The Developer has a responsibility to notify builders or purchasers of individual lots of the presence and location of any manholes which are located on the lot, that the manholes may not be buried or otherwise covered, and of the Builders responsibilities described in 3.4.2 below. The location and elevation of the stub end of the sewer lateral shall also be shown on the record drawings.

3.4.2 Builder

The Builder has a responsibility to flag and protect the manholes during his construction and re-grading process. Any damage to the manholes during his construction shall be the responsibility of the Builder, and the Builder will pay for all necessary repairs, inspection, and testing.

The Builder has a responsibility to inform the Plumber of the responsibilities described in 3.4.3 below and of the location of the service lateral stub so the Plumber can properly plan his work. The Builder also has a responsibility to inform the property owner of the presence of a manhole on the lot and that the manhole cannot be covered or buried. Manholes will be checked to confirm they have not been covered.

3.4.3 Plumber

The Plumber has a responsibility to locate the service lateral stub prior to beginning his work and to plan the residential or commercial plumbing system such that the existing tees and service lateral stubs can be utilized for connection to the sanitary sewer system. Failure to properly plan the plumbing system or to locate the service lateral stub shall not be a valid reason for tapping the main sewer line.

The Plumber shall install a cleanout at the end of the service lateral consistent with Standard Sanitary Sewer Drawing No. 234. The cleanout shall also serve as the plumbing test tee. The intent is to completely test all installed lines in either the sanitary sewer air test or the plumbing pressure test as well as providing a maintenance access point. The house lateral and the connection to the sewer lateral shall be left uncovered until it is inspected by the Division of Engineering.

3.4.4 Utility Companies

Utility companies shall plan their work and/or that of their subcontractors to avoid damage to the sanitary sewer system. Utility locations to serve new developments shall be planned early in the design process so the Engineer can include the location of all utilities and utility easements in the sanitary sewer plans.

Any damage to the sanitary sewer system caused by the installation of utilities shall be the responsibility of and repairs shall be paid for by the Utility Company that did the damage. Work by subcontractors shall be the responsibility of the Utility Company for which they are working.

Utilities that are installed closer than permitted to the sanitary sewer system shall be required to be relocated at the expense of the offending Utility Company. The Utility Companies shall inspect their work and maintain proper separation from the sanitary sewer.

3.5 Record Drawings

3.5.1 *Format for Record Drawings*

Record Drawings shall be submitted in the following format:

- Paper format
- Electronic format, AutoCAD Release 14 (or latest version)

3.5.2 *Requirements for Record Drawings*

Record drawings shall have a title block indicating that the drawings are Record Drawings, the name of the company preparing the Record Drawings, and the date the Record Drawings were prepared. Record Drawings shall be certified correct and complete by the Engineer.

Drawings shall be legibly marked for all construction and underground utilities and include the following:

- Changes of dimension and detail
- Changes made by Requests for Information (RFI), field order, clarification memorandums or by change order
- Details not on original Drawings
- Horizontal and vertical locations of all exposed and underground utilities and appurtenances, both new facilities constructed and those utilities encountered, referenced to permanent surface improvements. This shall include, but not be limited to, all mains, valves, water service locations, sewer lateral locations, manholes, fittings, fire hydrants, piping arrangements, and electrical conduits within the completed facilities.
- Location of and dimensions of roadways and parking areas, providing dimensions to back of curb when present
- Depths of various elements of foundation in relation to finish first floor datum or top of wall
- Location of internal and buried utilities and appurtenances concealed in the construction, referenced to visible and accessible features of the structure
- For sewers, the Record Drawings shall include the horizontal angle and distance between manhole covers.
- For force mains, the profile of the top of the pipe shall be provided. Elevations, not depths, shall be provided at a minimum 100-foot interval and at all bends, high points, low points, air valves, and where elevations are called out on the Drawings.

- Record drawings shall show addresses, data seals, and all construction changes.

3.5.3 Precision for Record Drawings

Precision for the Record Drawings shall be as Follows:

- Record Drawings shall provide horizontal dimensions, distances, and coordinates to the nearest 0.1 foot.
- Record Drawings shall provide elevations to the nearest 0.01 foot for all pertinent items constructed by the Contractor.
- For gravity sewers, the Engineer shall employ a currently Registered Surveyor (in the Commonwealth of Kentucky) to prepare the Record Drawings from a post-construction, field run survey. The Record Drawings shall provide elevations to the nearest 0.01 foot for all manhole inverts, manhole frames, and other pertinent items constructed by the Contractor. The Record Drawings shall provide dimensions, distances, and coordinates to the nearest 0.01 foot and horizontal angles to the nearest 10 seconds.

3.6 System Acceptance by the LFUCG

Prior to the LFUCG accepting any system, including gravity sewer systems, and pumping stations, the following conditions shall be met:

- Satisfactory completion of all required testing
- Satisfactory completion of the operating demonstration for all pumping stations
- Receipt of all required shop drawings, operating information, O & M manuals etc. as defined by this manual
- Receipt and acceptance by the LFUCG of complete, accurate Record Drawings, certified by the Engineer, which represent the actual constructed sanitary sewer system
- Certification of the Engineer that the system was constructed in accordance with the original plans and specifications
- Copies of Releases of Liens for all contractors, subcontractors, engineers, material suppliers, manufacturers etc. who have been involved in the project

CHAPTER 4 FLOW DETERMINATION

4.1 Drainage Area

Sanitary sewers and pumping stations shall be designed to serve the entire drainage area.

Wastewater flows shall be calculated using the best available information for the drainage area. The current proposed development, all known future developments, and allowances for undeveloped land must be included in the flow calculations. The maximum number of units allowed by current zoning shall be used for undeveloped areas.

Allowances for undeveloped land must consider the current zoning of the land, possible future zoning changes, land-use planning documents, location of the land relative to the Urban Services Area boundary, and any other relevant information as well as input from the Division of Planning, Division of Engineering, and Division of Water Quality.

4.2 Flow Calculations

In the absence of data to the contrary, sanitary sewers and pumping station capacity shall be determined by using the information provided in Table 4.1–Wastewater Flows and Table 4.2–Peaking Factors.

TABLE 4.1 – WASTEWATER FLOWS

Development Type	Design Flow Per Unit	Avg. Flow Rate Per Unit
	gpd	gpm
Single Family	400	0.28
Duplex (2 units)	400	0.28
Condominiums	400	0.28
Private Estates	400	0.28
Townhouses and Apartments	400	0.28
Residential unit	400	0.28
	gpd / acre	gpm / acre
Commercial	2,000	1.39
Industrial	3,600	2.50
Non-developable Land	100	0.07

Calculations shall also be provided showing the capacity of the existing sewer system to receive the projected flows. After obtaining the average flow rate from Table 4.1, a peaking factor shall be applied from Table 4.2 to obtain the design flow rate.

TABLE 4. 2 – PEAKING FACTORS

Average Daily Flow Rate gpd	Average Daily Flow Rate gpm	Tributary Population	Ratio Of Peak Instantaneous Flow Rate To Average Daily Flow Rate
<100,000	<69	<1,000	5.0
100,000-300,000	69-208	1,001-3,000	4.7
300,000-400,000	208-278	3,001-4,000	4.6
400,000-600,000	278-417	4,001-6,000	4.4
600,000-800,000	417-556	6,001-8,000	4.0
800,000-1,000,000	556-694	8,001-10,000	3.8
1,000,000-1,500,000	694-1,042	10,001-15,000	3.6
1,500,000-2,000,000	1,042-1,389	15,001-20,000	3.4
2,000,000-3,000,000	1,389-2,083	20,001-30,000	3.2
3,000,000-4,000,000	2,083-2778	30,001-40,000	3.0
4,000,000-6,000,000	2778-4167	40,001-60,000	2.8
6,000,000-8,000,000	4167-5556	60,001-80,000	2.7
8,000,000-10,000,000	5556-6944	80,001-100,000	2.6
>10,000,000	>6944	>100,000	2.5

4.3 Example Calculation

Assume a 250-acre tract is to be developed and will require a sewage pumping station. In addition, an additional 100 acres lies on the same watershed above the proposed development and is to be considered in the sizing of the pumping station and trunk sewer. Calculations are presented in Table 4.3, Example Calculations.

TABLE 4.3 – EXAMPLE CALCULATIONS

Development Type	No. Acres	No. Units	Avg. Flowrate Per Unit (gpm)	Avg. Flowrate Per Unit (gpd)	Avg. Flowrate (gpd)	Design Flow Rate (gpd)
Single	150	480	0.28	400	192,000	
Duplex	30	180	0.28	400	72,000	
Condominium	50	300	0.28	400	120,000	
Apartments	20	220	0.28	400	88,000	
Flow rate for Development					472,000	
From Neighborhood Plan Showing Proposed Land Use						
Singles	55	85	0.28	400	34,000	
Estates	45	50	0.28	400	20,000	
Flow rates for Off-site Upstream					54,000	
Avg. Total Flow - gpd					526,000	
Population Equivalent					5,260	
Peaking Factor					4.4	
Design Flow - gpd						2,314,400
Design Flow - gpm						1,607

CHAPTER 5 COMPUTER MODELING

5.1 Computer Modeling

5.1.1 General

The LFUCG is developing an existing sanitary sewer system computer model. Once these models are completed, the LFUCG may require that all additions to the sanitary sewer system be submitted in an electronic format consistent with the adopted model.

If plans and/or other design information are generated using static modeling systems such as AutoCAD or Eagle Point software, that information shall be submitted to the LFUCG in its electronic format.

CHAPTER 6 SANITARY SEWERS

6.1 General

This section contains the criteria necessary to design sanitary sewers. Flow rates shall be determined using the flow information from Section 4.0–Flow Determination.

6.2 Collector Sewers

Collector sewers are primarily installed to receive wastewater directly from property sewer laterals and transport the wastewater to trunk sewers.

Collector sewers are 10 inches or less in diameter.

Collector sewers shall not be located in detention/retention basins or the embankments that create the basin, drainage rights of way, or in the 10-year flood plain.

6.3 Trunk Sewers

A trunk sewer is a principal sewer to which collector sewers are tributary. Trunk sewers shall be designed to handle the drainage area/watershed above them consistent with Section 4.0–Flow Determination.

Trunk Sewers are 12 inches in diameter and greater.

Trunk sewers shall not be located in storm retention basins or the embankments that create the basin, drainage rights of way, or in the 10-year flood plain.

6.4 Hydraulic Design Criteria

6.4.1 Manning's Equation

Use Manning's Equation to determine the proper size and slope to transport the design flow. For design purposes, the roughness coefficient shall be considered 0.013 regardless of the proposed pipe material.

6.4.2 Collector Sewer Criteria

Design collector sewers as follows:

- Design for full flow conditions
- Minimum Velocity - 2 ft./second
- Maximum velocity - 10 ft./second
- Minimum allowable slopes - See Table 6.1 below.

6.4.3 Trunk Sewer Criteria

Design trunk sewers as follows:

- Design for two-thirds (2/3) full condition
- Minimum Velocity - 2ft./second
- Maximum Velocity - 10 ft./second
- Minimum allowable Slopes - See Table 6.1 below.

TABLE 6.1 – MINIMUM ALLOWABLE SLOPES

Diameter, Inches	Slopes, %	Slopes, ft./ft.
8	0.40	0.004
10	0.28	0.0028
12	0.22	0.0022
15	0.15	0.0015
16	0.14	0.0014
18	0.12	0.0012
21	0.11	0.0011
24	0.08	0.0008

6.5 Manholes

6.5.1 Location

Manholes shall be located at all changes in pipe grade, pipe size, alignment, pipe intersections and at the end of a run of pipe.

6.5.2 Spacing

For pipes 15 inches and smaller, spacing shall not exceed 400 feet, maximum. For pipes larger than 15 inches, spacing shall not exceed 500 feet, maximum.

6.5.3 Size

A minimum 4-foot diameter manhole shall be used for pipes less than 15-inches diameter. Pipes 15 inches to 24 inches in diameter shall utilize a four- (4) or five- (5) foot diameter, depending on the deflection angles. See the Standard Sanitary Sewer Drawing No. 217 for the manhole sizing guide. Pipes larger than 24 inches in diameter to 36 inches in diameter require a five- (5) foot diameter manhole.

6.5.4 Elevations

The elevation of the nearest downstream manhole lid shall be at least one (1) foot below the lowest plumbing fixture in a structure. The intent is to eliminate the possibility of a clogged or overloaded sewer backing up into a structure, damaging the structure or its contents, or creating a health hazard for the occupants.

The elevation of manhole lids shall be at least one (1) foot above the 100-year flood elevation.

Manholes and sanitary sewer pipes shall not be located in storm retention basins or the embankment creating the basin, or the 10-year flood plain.

6.5.5 Manhole Frames and Covers

Manhole frames and covers shall be consistent with Standard Sanitary Sewer Drawing No. 220. Adjustable frames and covers shall be consistent with Standard Sanitary Sewer Drawing No. 221. Watertight frames and covers shall be consistent with Standard Sanitary Sewer Drawing No. 222.

6.5.6 Manhole Bench

Benches in manholes shall be one pipe diameter for pipes greater than 10 inches and one-half pipe diameter for pipes 10 inches or less. The bench shall slope upward from the flow channel to the walls of the manhole, per LFUCG Standard Drawing #213. All inlets shall have a flow channel.

6.5.7 Existing Brick Manholes

There shall be no new connections to existing brick manholes. Where connections are necessary to an existing brick manhole, the brick manhole shall be replaced with a new manhole that meets the specifications of the LFUCG standard drawings.

6.6 Pipeline Depth

Sewers shall be designed to meet the following depth requirements:

- Minimum four feet of cover, unless sewer is constructed with ductile iron pipe, whereby the minimum cover shall be two and a half (2.5) feet.
- Top of the pipe shall be two and a half (2.5) feet below a stream, creek, or ditch when it is crossed.
- Such a depth to allow proper connections of service laterals from the probable structure location.

Reference is made to Standard Sanitary Sewer Drawing No. 204 that provides details of acceptable fill depths for various pipe materials.

6.7 Sewer System Integrity

In locations where the sanitary sewer may be exposed to non-routine installation conditions, the sewer shall be constructed using ductile iron pipe. These conditions include, but are not limited to:

- Where depth of cover is less than four (4) feet
- Where depth of cover is greater than allowed by Standard Sanitary Sewer Drawing No. 204.
- Where the sewer crosses under a creek or stream.
- Where ductile iron pipe is used, it shall extend from manhole to manhole.
- Where the sewer is constructed of ductile iron pipe, the sanitary sewer service lateral from the main to the property line or easement line shall be ductile iron.

Where the sewer crosses over a storm drain pipe, PVC pipe is allowed, but the sewer joints shall be equidistant from the storm sewer trench.

The Engineer shall contact the Division of Engineering to determine the protection measures necessary when a sanitary sewer is proposed to cross under a new or existing storm drain pipe if the outside wall of the storm drain pipe will be within 18 inches vertically of the outside wall of the sanitary sewer.

The Engineer shall contact the Kentucky Division of Water to determine the protection measures necessary when a sanitary sewer is proposed to cross over or under an existing water main if the outside wall of the water main will be within 18 inches vertically of the outside wall of the sanitary sewer.

6.8 Other Requirements

6.8.1 Service Laterals

Service laterals to single family houses shall be four (4) inch diameter from a four (4) inch tee. Service laterals longer than five (5) feet in length shall be six (6) inches in diameter. Service laterals from the main to the property line or easement line shall be of the same material as the main. If two (2) or more residential units are connected to a common lateral, the line and tee shall be six (6) inch diameter. For commercial or multi- family connections the lateral shall be sized based on the number of units but in no case less than six (6) inches in diameter. Service laterals shall not be located in storm retention basins or the embankments that create the basin.

Six inch diameter laterals serving single family residential units shall be constructed with a cleanout at the end of the lateral where it enters the lot. These laterals shall be shown on the record drawings and shall be subject to the sewer testing requirements in Section 3.2.

The Engineer shall contact the Division of Engineering when a service lateral is to be connected to a manhole. All service laterals connecting to manholes (when approved) shall have a flow channel.

The Developer shall be responsible for installation of necessary additional laterals within the three-year warranty period. Any installation of laterals that were not shown on the Improvement Plans accepted by LFUCG shall meet new construction specifications. This includes installation of only rigid factory tees (no saddles shall be allowed.)

6.8.2 Water Main Separation

Sewers shall be laid at least ten (10) feet horizontally from existing or proposed water lines. The distance shall be measured edge of pipe to edge of pipe.

Sewers crossing water mains shall be laid to provide a vertical distance of 18 inches between the outside of the water main and the outside of the sewer. This shall be the case where the water main is either above or below the sewer. The crossing shall be arranged so that the sewer joints will be equidistant and as far as possible from the water main joints. Where a water main crosses under a sewer, adequate structural support shall be provided for the sewer to prevent damage to the water main.

6.8.3 Sewer in Fill Areas

Subgrade and backfill for sewers located in fill areas shall be compacted to not less than 95 percent of density determined from the Standard Proctor Test, or to not less than 90 percent of the density determined by the Modified AASHTO Method (AASHTO T-99).

6.9 Easements

6.9.1 General

Easements are often shared for the installation of several different utilities. Sanitary sewers, storm sewers, underground or overhead electric, cable television, and telephone are often in the same utility easement competing for space. With this being the case, it is extremely important that the easements and the utilities to be located in the easement be defined as early as possible in the design process. This information shall be included in the plans submittal to the Division of Engineering.

Sanitary sewers and storm sewers in the same easement shall be a minimum of four (4) feet off the property line, located on opposite sides of the property line, and not closer than two (2) feet from the outside edges of the easement. Underground electric service shall be separated from them by a minimum of six (6) feet. Sanitary sewers and storm sewers shall be spread further apart to allow underground electric to run between the two and the easement may be off-center relative to the property line to allow a good distribution of the various utilities in the easement. No other utilities may share the same trench with the sanitary or storm sewers and if any other utility is installed in error in the same trench, it shall be moved. No reason, including efforts to avoid rock, will be considered valid for not relocating utilities installed over the sanitary or storm sewer.

6.9.2 Variances and Encroachments

No structure shall be permitted in, on, over, or under the land within the easement. Developers and their Engineer shall plan the utilities, easements, property lines, and other features of the development so that homeowner improvements will not encroach on the easement. At-grade patios (without footings), slabs on grade (without footings), sidewalks, driveways, and permitted privacy fences with non-structural posts (no brick or masonry columns) are permitted in the easement.

6.9.3 Required Easement Widths

The required width of an easement varies based on the utilities that will be located in the easement. Table 6.2 addresses the required easement width.

TABLE 6. 2 – EASEMENT WIDTHS

Utilities in Easement	Width Required -ft. (min.)
Sanitary Sewer < 10 ft. deep	15
Sanitary Sewer > 10 ft. deep	20
Sanitary Sewer < 10 ft. deep & Storm or U.G. Electric (only 1)	15
Sanitary Sewer (any depth) & Storm & U.G. Electric	20
Force Mains (alone)	12
Force Mains-with any other single utility	15
Force Mains-with multiple other utilities	20 Additional width may be required if all utilities occupy same easement
Overhead Electric, Cable TV, Telephone, Street Light, or other small size utilities	May be included in any easement without additional width, but may not occupy same trench as sewers. Electric poles must be set to avoid all other utilities

CHAPTER 7 PUMPING STATIONS

7.1 Administrative Procedures

7.1.1 General

The use of a pumping station shall be considered only when the area cannot be served by gravity sewers, including reasonable extensions to existing or proposed gravity lines. Multiple small pumping stations in lieu of a larger single pumping station shall not be permitted. At such time that an Engineer/Developer becomes aware of the need for a sewage pumping station, he shall immediately advise the Division of Engineering and the Division of Water Quality and arrange for a meeting with them. Prior to the meeting, the Engineer/Developer shall review article F. INTERIM FACILITIES, and ALLOCATION OF SYSTEM CAPACITY, pages II-6 through II-12 of the LFUCG adopted IMPLEMENTATION PLAN FOR CONSTRUCTION OF THE OUTER PERIMETER SEWERAGE SYSTEM - 1986, and any subsequent amendments to these documents or the 201 Facilities Plan. The Engineer/Developer shall provide the following information for discussion and consideration at the meeting:

- General location and elevation of proposed pumping station and 100 year flood.
- Approximate capacity in gallons per minute.
- Probable points of discharge to existing or proposed systems.
- Area of proposed service.
- Development and construction schedule.
- Relationship of proposed system to existing and/or other proposed systems and capability of existing system to serve proposed areas.
- Future tie-in by others with a reimbursement schedule.
- Proposed rights of way, easements, etc. for roads, turnarounds, and utilities.

This initial meeting shall result in a decision by the Commissioner of the Department of Public Works/Development and the Commissioner of the Department of Environmental Quality that the proposed pumping station is premature or appropriate according to the implementation plan or that the proposed development can be served by existing or other proposed facilities without the necessity of an additional pumping station.

7.1.2 *Design of Pumping Station*

Design shall be in accordance with this manual and all other applicable rules and regulations. Design drawings and specifications shall be stamped by a Professional Engineer licensed by the Commonwealth of Kentucky.

7.1.3 *Design Approval Process*

Upon completion of the design of the pumping station, the following shall apply

- An initial submittal of three (3) sets of final plans and specifications for the proposed pumping station shall be submitted to the Division of Engineering and the Division of Water Quality. After review and acceptance by the Division of Engineering and the Division of Water Quality, the Engineer shall submit the plans to the Kentucky Department of Environmental Protection for approval.
- Along with the submittal to the Kentucky Department for Environmental Protection for approval of plans and specifications, a request should be made for a required permit from the Kentucky Department for Environmental Protection.

7.2 Classes of Pumping Stations

Sanitary sewage pumping stations shall be divided into four (4) classes based on the pumping capacity. They are:

- Class A - 3,000 gpm and greater
- Class B - 1,000 gpm to 2,999 gpm
- Class C - 75 gpm to 999 gpm
- Class D - less than 75 gpm

7.2.1 General Requirements – Class A and Class B Pumping Stations

Class A and B pumping stations shall be designed to pump the ultimate design capacity of the drainage area. Class A and B pumping stations may be submersible or dry-pit pumping stations. Class A and B pumping stations shall have the following components:

- Building
- 1-inch open, mechanically cleaned bar screen if influent sewer is 30” diameter or larger
- Flow measurement and recording
- Odor Control
- Emergency Power Generator
- Telemetry/SCADA System
- Concrete, cast in-place wet well
- Minimum of three (3) pumps and pumping compartments
- Fencing as required
- Landscaping as required
- Access Roads and Turnarounds

Class A and B pumping stations generally will be planned, designed, and constructed by contract with the LFUCG. Class B pumping stations may be planned, designed, and constructed by a Developer. Additional information on the required components is provided in Section 7.4 Details of Class A and B Pumping Stations.

7.2.2 General Requirements – Class C and Class D Pumping Stations

Requirements for Class C and D pumping stations are very similar to each other and considerably different from Class A and B pumping stations. Class C and D pumping stations shall have the following components:

- Emergency Power Portable Hookup
- Telemetry System
- Precast Concrete Components
- Minimum of two (2) submersible pumps required, and tin can type buried pumping stations not permitted. Multiple wet wells are required for Class C, a single wet well for Class D

- Fencing
- Landscaping as required
- Access Roads and Turnarounds
- Odor control, if necessary

7.2.3 Pumping Stations Permanent

All pumping stations are considered permanent and shall be designed to these standards.

7.2.4 Pumping Station Class Requirements

Table 7.1 summarizes the various requirements of Class A, B, C, and D pumping stations.

TABLE 7.1 - REQUIREMENTS FOR PUMPING STATIONS

Components	Class A P.S. 3,000 & > gpm	Class B P.S. 1,000-2,999 gpm	Class C P.S. 75-999 gpm	Class D P.S. <75 gpm
Building - 3 Room Min. & B.R.	Yes	No	No	No
Building - 2 Room Min.	No	Yes	No	No
Bar Screen	Yes ⁽¹⁾	Yes ⁽¹⁾	No	No
Flow Measurement	Yes	Yes	No	No
Odor Control	Yes	Yes	Possible	Possible
Emergency Power Generator	Yes	Yes	No	No
Emer. Power Portable Hookup	No	No	Yes	Yes
3 Phase Electrical Power Required	Yes	Yes	Yes	Yes
Telemetry	Yes	Yes	Yes	Yes
Cast in Place Concrete Required	Yes	Yes	No	No
Precast Concrete Allowed	No	No	Yes	Yes
Submersible Pumps Allowed	Yes	Yes	Yes	Yes
Dry Pit Pumps Allowed	Yes	Yes	No	No
3 Pumps Minimum	Yes	Yes	No	No
Multiple Wet wells Required	Yes	Yes	Yes	No
Fence	Yes	Yes	Yes	Yes
Paved Access & Turnarounds	Yes	Yes	Yes	Yes

⁽¹⁾ Required if influent sewer is 30” in diameter or larger.

7.3 Hydraulic Design Criteria

7.3.1 Wet Well Sizing

Class A, B, and C pumping stations utilize the double wet well arrangement. Class D pumping stations utilize a single wet well. Wet wells should be sized such that the electric motors will not start more than once every ten (10) minutes, assuming only one (1) pump is operating. The Engineer shall provide manufacturer's pump and motor data to document the permissible number of motor starts.

The critical flow rate is when the inflow to the pumping station wet well is exactly one half (1/2) of the sewage pump capacity. The formula for determining the minimum operating volume of the wet well is as follows:

$$\text{Cycle Time} = \text{Time to Fill} + \text{Time to Draw Down}$$

$$\text{Time to Fill} = \text{Volume}/\text{Influent Rate}$$

$$\text{Time to Draw Down} = \text{Volume}/(\text{Pump Rate} - \text{Influent Rate})$$

Cycle time is shortest when:

$$\text{Influent Flow Rate} = \frac{1}{2} \text{ Pump Rate}$$

$$\text{Cycle Time} = \frac{\text{Volume}}{\frac{1}{2} \text{ Pump Rate}} + \frac{\text{Volume}}{\text{Pump Rate} - \frac{1}{2} \text{ Pump Rate}}$$

$$\text{Cycle Time} = \frac{\text{Volume}}{\frac{1}{2} \text{ Pump Rate}} + \frac{\text{Volume}}{\frac{1}{2} \text{ Pump Rate}}$$

$$\text{Cycle Time} = \frac{\text{Volume (4)}}{\text{Pump Rate}}$$

Rearranging the formula gives the required wet well volume

$$\text{Volume} = \frac{(\text{Cycle Time}) (\text{Pump Rate})}{4}$$

or for a 10 minute cycle time

$$\text{Volume (gal)} = 2.5 \text{ Pump Rate (gpm)}$$

7.3.2 Example

If the pumping rate is 400 gpm, the critical flow rate for sizing the wet well is 200 gpm.

Wet well Volume = 2.5 (400 gpm)

Wet well Volume = 1,000 gallons

7.3.3 Force Main Sizing

The Kentucky Department for Environmental Protection, Division of Water, generally requires that a force main shall be sized to maintain velocity of 2 feet per second in the force main.

Table 7.2 provides the minimum flow rates necessary to maintain a minimum velocity of 2 feet per second.

TABLE 7.2 – FORCE MAIN SIZING

Pipe Diameter Inches	Min. Flow Rate gpm
4	75
6	180
8	325
10	500
12	700
14	1,000
16	1,250
18	1,600
20	2,000
24	2,850
30	4,500

The minimum allowable size force main is 4 inches in diameter.

Upper limits on velocities in sewage force main will generally be controlled by head loss concentrations; however, a velocity of 5 feet per second shall not be exceeded.

The C factors used for design of force mains are:

- PVC

C	=	140
Check at C	=	120 and 160

- Cement lined Ductile Iron

C	=	100
Check at C	=	90 and 140

7.3.4 Factors Affecting Pump Selection

Other factors shall be considered in the design of pumping stations and their components. These factors include:

- Use of variable frequency drives (VFD's) with the pumps. VFD use may affect wet well and pump sizing.
- Effects of one (1) or two (2) pumps operating. When the force main is close to a larger size being required very little, if any, additional capacity can be obtained from operating two (2) pumps at once. Selection of the larger size force main may permit the second operating pump to add to the station capacity at peak flow periods. This should not be considered if the minimum velocity with one (1) pump operating will be less than 2 feet per second.
- Effects on the operation of the pumping station if the total dynamic head, TDH; friction head, Hf; static head, Hs; or C factor differs from the design values.
- Selection of pumps, motors, and impeller such that a larger impeller may be added to the pump to increase capacity without a required motor change.

Consideration of these factors is not meant to imply that all possible variables can be handled or designed into every system, but only that the Engineer should evaluate all factors so the resulting selections are the best possible under the design conditions.

7.4 Class A and B Pumping Station Details

7.4.1 Class A and Class B Buildings

Buildings shall have separate rooms for the electrical equipment including pump control panel and telemetry panel, bar screen, and odor control equipment (Class B odor control equipment may be outside). Class A buildings shall include a restroom. Standby power generators may be located in a separate room in the building or may be housed in a manufacturer's pad-mounted, outdoor generator enclosure. The electrical room shall be air conditioned for equipment cooling. All rooms shall have appropriate forced ventilation and humidity control. The building shall be constructed such that it is architecturally compatible with the surrounding area, including house/buildings.

7.4.2 Class A and Class B Bar Screen

A bar screen is required if the influent sewer is 30" diameter or larger. The bar screen shall be housed in a separate room in the building. The bar screen shall be mechanically cleaned with ¾-inch openings. Controls shall be located in the electrical room and housed in Nema 4 control panel and operate based on a variable timer or channel flow level sensor. Auxiliary contacts shall be provided so the screen can be monitored by the telemetry system. All equipment in this room shall be explosion proof in accordance with NFPA 820.

7.4.3 Class A and Class B Flow Measurement

Sewage flow shall be measured using a Parshall flume and recorded utilizing a circular chart recorder located in the electrical room of the building. Auxiliary contacts shall be provided so the flow can be monitored by the telemetry system. When excessive depth is involved, an ultrasonic (doppler) flow meter or a magmeter may be used on the effluent force main.

7.4.4 Class A and Class B Odor Control

Required odor control measures will vary depending on the installation and its location. Consideration should be given to systems for the local odors, such as sodium hypochlorite systems, as well as force main discharge manhole odors that may require a Bioxide system.

7.4.5 Class A and Class B Emergency Power

Full emergency power generation equipment shall be provided. This equipment may be housed in a separate room in the building or in a manufacturer's pad-mounted, outdoor generator enclosure. Consideration shall be given to the noise levels in the surrounding areas. Fuel tanks for Class A stations shall be separate from the enclosure, Class B fuel tanks may be integral to the generator enclosure. Fuel tanks shall be sized to permit approximately 24 hours of run time.

7.4.6 Class A and Class B Telemetry System

Class A and B sewage pumping stations shall be provided with telemetry equipment sensors compatible with LFUCG’s provided telemetry system. The system is a Motorola INTRAC 2000 microprocessor-based system, with a repeater station and computer-based master station. The system utilizes a radio communication system with pumping station radios transmitting on 808.63750 MHz and receiving on 853.63750 MHz.

Table 7.3 provides the signals required to be monitored at each pumping station.

TABLE 7.3 – CLASS A & B TELEMETRY REQUIREMENTS

Monitoring Point	Submersible Pumping Station		Dry Pit Pumping Station	
	Monitor	Required Signals	Monitor	Required Signals
Pump Run for Each Pump	Yes	3 min.	Yes	3 min.
Power Failure	Yes	1	Yes	1
Generator Run	Yes	1	Yes	1
High Wet well	Yes	1	Yes	1
Telemetry Fail	Yes	0	Yes	0
Water on the Floor	No	0	Yes	1
Building Intrusion	Yes	1	Yes	1
Telemetry Panel & Control Panel Intrusion	No	0	No	0
Combustible Gas Detection	Yes	1	Yes	1
Overflow	Yes	1	Yes	1

These status signals shall be monitored as described below.

- Pump run shall be monitored utilizing an auxiliary contact from the pump motor starter.
- Power failure shall be monitored using a three-phase power monitor. The power monitor shall provide a closed contact output upon detecting a power failure and shall be TIME MARK model 258 or 260 (single-phase) or equal.
- Generator run shall be monitored off an auxiliary contact in the generator control panel.
- High wet well level shall be monitored utilizing a mercury float switch mounted in the wet well. The float shall be mounted at an elevation to provide a closed contact output when the wet well water level is approximately 1 foot below the overflow. The actual float elevation shall be field-determined by the LFUCG. The float cable shall be of

sufficient length to terminate wiring in the control panel without splicing. The float switch shall be Consolidated Electric Model LS or equal.

- Telemetry failure is internal to the communication equipment and shall be monitored at the master station.
- Water on the floor shall be detected utilizing a bracket-mounted float switch mounted on the wall just above the floor. The switch shall provide a closed-contact output, if water on the floor raises the float switch. The float switch shall be DELAVAL GEMS LS-270, or equal.
- Building intrusion shall be monitored by a limit switch mounted on the interior door frame that provides a closed contact when the building door(s) is open.
- Combustible gas shall be monitored by a contact in the combustible gas detection system panel.
- Overflow shall be by a float switch in the same manner as the high wet well level.

The radio communications equipment and the monitor/control unit shall be housed in a NEMA 4 enclosure suitable for outdoor use. The telemetry system shall be provided by LFUCG, complete with antenna, coaxial cable, conduit, wire, and miscellaneous appurtenances necessary to provide a complete, functioning system.

The telemetry master station shall be modified, as necessary, by the LFUCG to add the proposed pumping station to the monitor system.

All necessary FCC licensing shall be obtained by the LFUCG for additional sites.

7.4.7 Class A and Class B Wet Wells

Wet wells, flow measurement channels and Parshall flume (with fiberglass insert), building foundation, and other structural components of Class A and B pumping station shall be cast-in-place concrete. Precast concrete components are not acceptable. Concrete flow channels and aluminum gates shall direct the sewage flow to the wet wells. Piping and valves are not acceptable.

All hardware in the wet wells including but not limited to guide rails, anchor bolts, chains, cables, mounting brackets, hinges, hinge pins, and other hardware on aluminum hatches, etc. shall be stainless steel or other approved non-corrosive material. Galvanized or coated steel is not acceptable.

Combustible gas monitoring equipment shall be mounted in a location convenient for maintenance purposes and consistent with the manufacturer's recommendations.

7.4.8 Class A and Class B Pumps

A minimum of three (3) pumps is required. Two (2) pumps shall be capable of pumping the design flow, and the third pump shall be standby. Depending on the size of the pumps compared to the ultimate pumping station capacity, additional pumps may be required. In a submersible pumping station with three (3) pumps, each pump shall be located in an individual wet well. Four (4) pumps may be located with two (2) in each wet well.

Controls for the pumps shall utilize an ultrasonic level control system.

7.4.9 Class A and Class B Fencing

Fencing is required for Class A and B pumping stations. Depending on the location of the pumping station, the surrounding area, potential for damage to outside equipment, and other factors, the Division of Water Quality may waive this requirement or allow a residential treated wood fence around selected outdoor components and equipment but not the entire site.

7.4.10 Class A and Class B Landscaping

Landscaping may be required based on the surrounding area.

7.4.11 Class A and Class B Access Roads and Turnarounds

Access roads and turnarounds shall be constructed of asphalt. Appropriate drainage, consisting of ditches, cross-drains, headwalls, catch basins, and the like shall be included in the design. Access roads and turnarounds shall be consistent with Standard Sanitary Sewer Drawing No. PS 413-0.

7.4.12 Class A and Class B Buffer Zones

The pump station structure shall be located a minimum of 300 feet from an existing or future residential structure.

7.5 Class C and D Pumping Station Details

7.5.1 Class C and Class D Building

A building is not required.

7.5.2 Class C and Class D Bar Screen

A bar screen is not required.

7.5.3 Class C and Class D Flow Measurement

Flow measurement and recording is not required.

7.5.4 Class C and Class D Odor Control

Odor Control provisions shall be required if the Division of Water Quality determines that odors will be a problem.

7.5.5 Class C and Class D Emergency Power

Emergency power generation equipment is not required. Provisions shall be made to allow a portable, trailer-mounted generator to be parked at the site and plugged in to power the pumping station.

Required components include:

- Manual switch to disconnect from utility power supply and Receptacle to plug in the portable generator.
- Receptacle shall be in accordance with the latest Division of Water Quality standard for the class pumping station and the total horsepower to be installed

7.5.6 Class C and Class D Telemetry

Telemetry system requirements are generally the same as Class A and B pumping stations with the exception that building intrusion signals are not necessary, since a building will not normally be a component of a Class C or D pumping station. Table 7.4 summarizes the telemetry requirements for Class C and D pumping stations.

TABLE 7.4 – CLASS C & D TELEMETRY REQUIREMENTS

Monitoring Point	Submersible Pumping Station	
	Monitor	Required Signals
Pump Run for Each Pump	Yes	2
Power Failure	Yes	1
Generator Run	No	0
High Wet well	Yes	1
Telemetry Fail	Yes	0
Telemetry Panel & Control Panel Intrusion	Yes	1
Combustible Gas Detection	Yes	1
Overflow	Yes	1

7.5.7 Class C and Class D Wet Wells

Wet wells for Class C and D, pumping stations may utilize precast concrete pipe/manhole sections. Class C pumping stations must have a minimum of two (2) wet wells. Class D pumping stations may have a single wet well. Piping and valves are acceptable to direct sewage flow to the wet wells.

All hardware in the wet wells including but not limited to guide rails, anchor bolts, mounting brackets, hinges, hinge pins, and other hardware on aluminum hatches, etc. shall be stainless steel or other approved non-corrosive material. Galvanized or coated steel is not acceptable.

Combustible gas monitoring equipment shall be mounted in a location convenient for maintenance purposes and consistent with the manufacturer’s recommendations.

7.5.8 Class C and Class D Pumps

A minimum of two (2) pumps is required for Class C and D pumping stations. One (1) pump shall be capable of pumping the design capacity, and one (1) pump will be standby.

7.5.9 Class C and Class D Control Enclosure

The control enclosure shall be aluminum or stainless steel and shall include a hasp for a padlock.

7.5.10 Class C and Class D Fencing

Fencing requirements are the same as Class A and B pumping stations.

7.5.11 Class C and Class D Landscaping

Landscaping requirements are the same as Class A and B pumping stations.

7.5.12 Class C and Class D Access Roads and Turnarounds

Access road requirements are the same as Class A and B pumping stations. Common driveways with adjacent property owners will not be allowed.

7.6 Force Main Details

7.6.1 Force Main Blocking

Refer to Drawing Number PS 406-0. All fittings along the route of the force main shall be blocked or restrained as shown on the detail sheets to prevent joint separation during operation.

7.6.2 Force Main Air Releases

Refer to Drawing Numbers PS 415-0 and 417-0. Automatic air releases should be installed on all major high points along the route of the force mains and manual air releases placed on the minor or sub-high points. These shall be shown on Record Drawings with accurate measurements for location.

7.6.3 Force Main Markers

Refer to Drawing Numbers PS 408-0 and PS 409-0. Force mains shall be sufficiently marked by concrete and/or steel markers to adequately locate the main for future reference. Markers shall be placed at every change of direction, street crossings, at an allowable sight distance (in fields or undeveloped areas), and Northing and Easting coordinates shown on the Record Drawings. Magnetic tape located above the force main is required for locating non-metallic force mains.

7.6.4 Force Main Discharge Point

Refer to Drawing Number PS 407-0. The discharge point of a force main (particularly long and/or large force mains) should be checked to determine if problems might arise from the discharge of septic sewage. Hydrogen sulfide (sewer gas) will be generated inside the force main and will be expelled at the discharge point.

If this appears to be a consideration, special treatment should be given to the design of the receiving manhole. Items such as underground venting, submerging the discharge, and preventing turbulence will help to prevent a nuisance at the discharge point.

The receiving manhole shall be epoxy coated on all inside surfaces to protect against corrosion.

In some situations, it may be necessary to aerate, chlorinate, use hydrogen peroxide, or provide other means to prevent or minimize the formation of the hydrogen sulfide gas.

7.6.5 Force Main Materials

PVC (SDR 21 minimum wall thickness), and ductile iron (Class 50 minimum) pipe shall be allowed for use in force main construction, dependent on specific conditions.

7.6.6 Force Main Isolation Valves

Where force mains tie into existing force mains, a gate valve shall be provided in the new force main at a point near the connection to the existing force main. The valve is to provide a means of isolating the force main in the case of a force main break.

7.7 Use of Approved Equipment

All equipment in all pumping stations must be on the approved equipment list maintained by the LFUCG Division of Water Quality.

APPENDIX A – CHECKLISTS

Pumping Station Checklist

Station Name _____

Station Type _____

Location _____

Job Number _____

Engineer _____

- _____ Flow Determination
- _____ O & M Cost Projections
- _____ Design Elevations
- _____ Head Calculations
- _____ Head & Performance Curves
- _____ Operating Conditions
- _____ Force Main Diameter Verifications (Economy)
- _____ Project Map (Location)
- _____ Site Plan
- _____ X-Section & Detail Sheet
- _____ Specifications
- _____ Hydraulic Gradient – Include in Submittal to Urban County Government

Head Curves Design Form

Sheet _____

Project _____

Date _____

Station _____

Job No. _____

By _____

Design Capacity _____

Design Static _____

Force Main Length _____

Force Main Size (Ø) _____

“C” Factor for Design _____

System Head Curve – Design - : Ø = _____ c = _____

<u>Rate</u>	<u>H Factor</u>	<u>Length/100</u>	<u>c =</u>	<u>Hf</u>	<u>Design Static</u>	<u>TDH</u>
-------------	-----------------	-------------------	------------	-----------	----------------------	------------

System Head Curve – Minimum Head, Maximum Discharge – Ø = _____ c = _____

<u>Rate</u>	<u>H Factor</u>	<u>Length/100</u>	<u>c =</u>	<u>Hf</u>	<u>Minimum Static</u>	<u>TDH</u>
-------------	-----------------	-------------------	------------	-----------	-----------------------	------------

Installation Type (check one)

SIMPLEX

DUPLEX

TRIPLEX

Station Type (check one)

SUBMERSIBLE

SUCTION LIFT

HORIZONTAL DRY PIT

VERTICAL DRY PIT

OTHER (Describe) _____

Operating Conditions

Item

Location

Design Capacity	_____	GPM
Design TDH:	_____	Ft.
Design Static Head:	_____	Ft.
Force Main Length	_____	Ft.
Force Main Size	_____	In. o
Design "C" Factor:	_____	
Min. Static Head:	_____	Ft.
Min. TDH (C = 160):	_____	Ft.
Max. Capacity @ Min. TDH:	_____	GPM

Pump

Design Efficiency	_____	%
Min. Solid Diameter	_____	In. o
Suction Size (Min.)	_____	In. o
Discharge Size (Min.)	_____	In. o

PUMP STATION TELEMETRY SYSTEM
FCC License Information

Physical Location of Station (verbal description)

Longitude: _____
Latitude: _____
Ground Elevation: _____

Street Address of Station (if applicable)

Additional Information

APPENDIX B – DRAWINGS

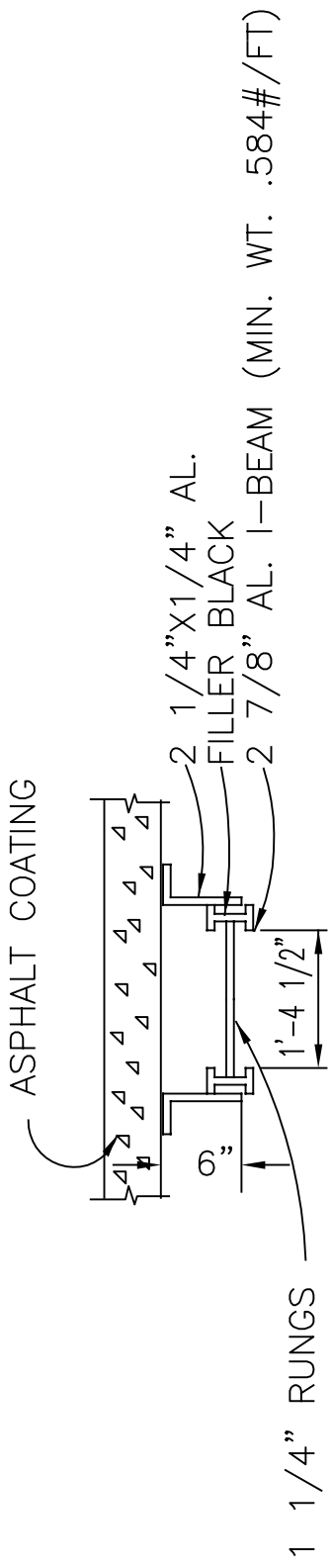

PLAN

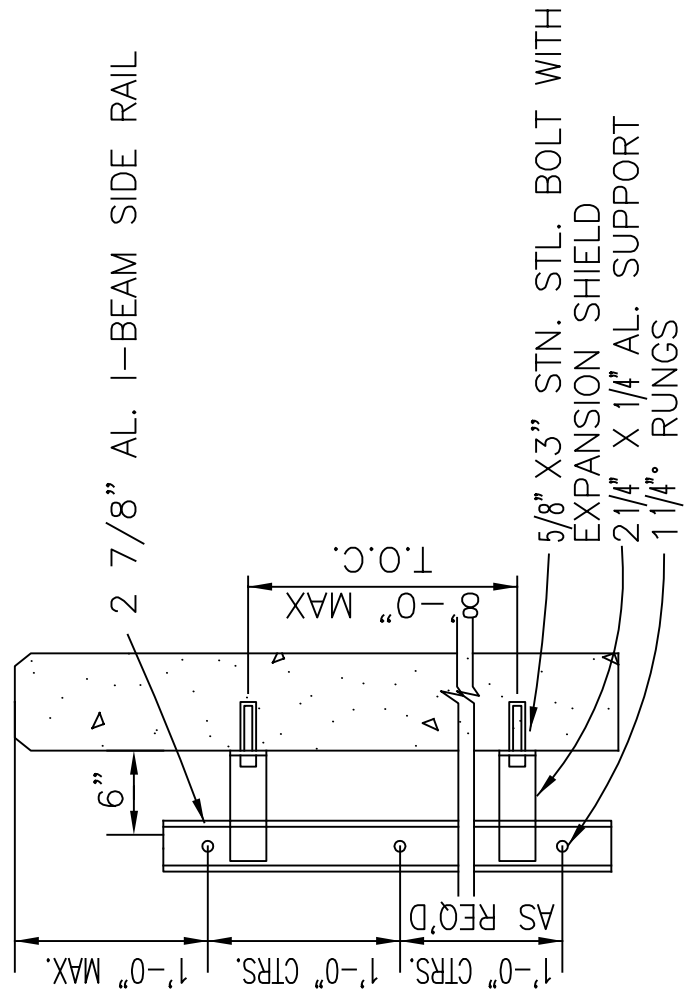

DETAIL

ALUMINUM LADDER
PLAN AND DETAIL

1/1/09

STANDARD SANITARY SEWER DRAWING NO.

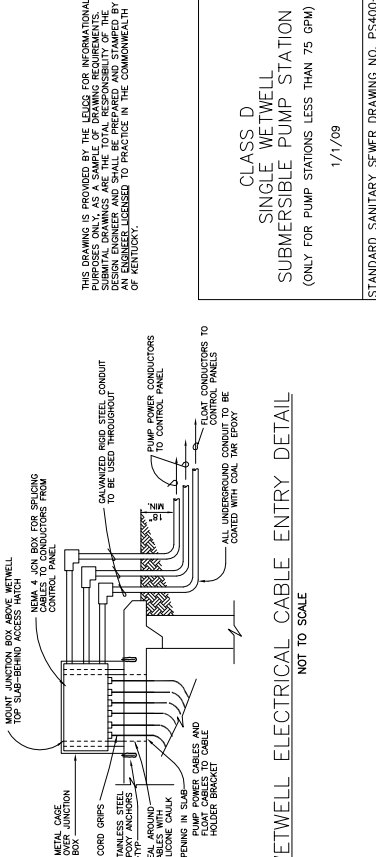
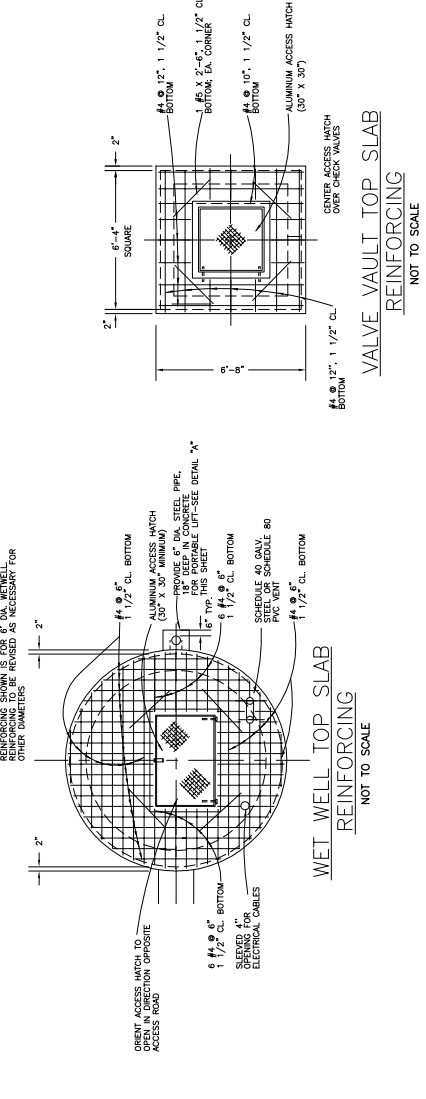
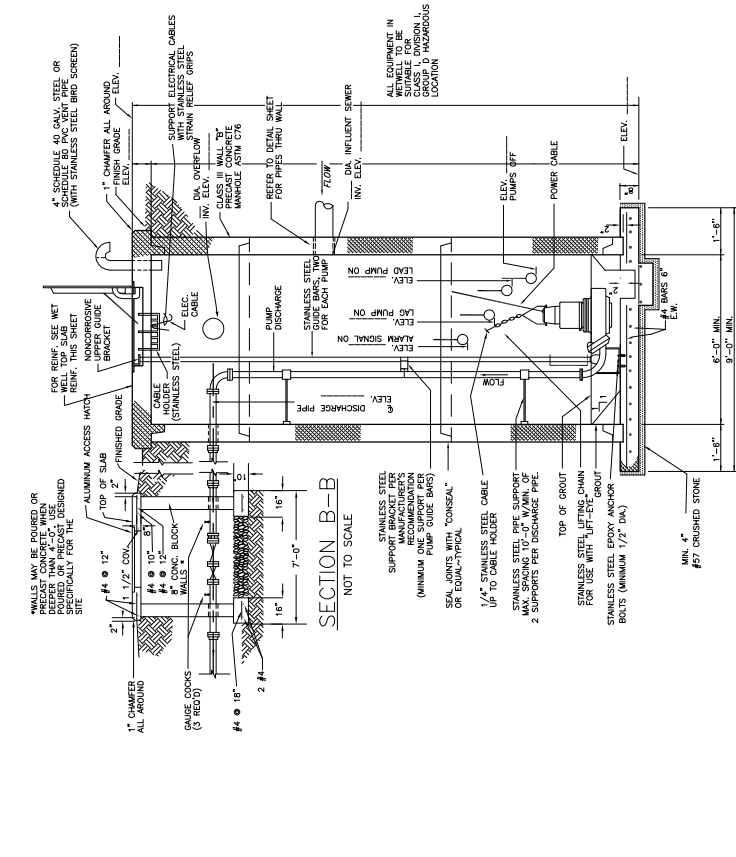
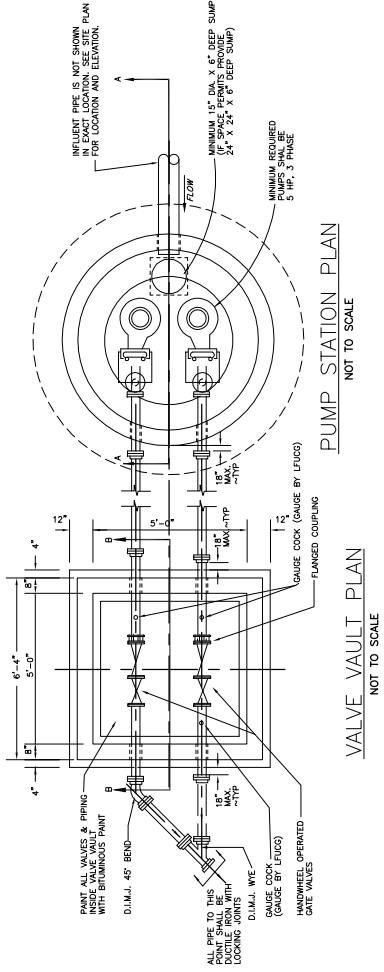

CLASS D
SINGLE WETWELL
SUBMERSIBLE PUMP STATION
(ONLY FOR PUMP STATIONS LESS THAN 75 GPM)

1/1/08

STANDARD SANITARY SEWER DRAWING NO. PS400-0

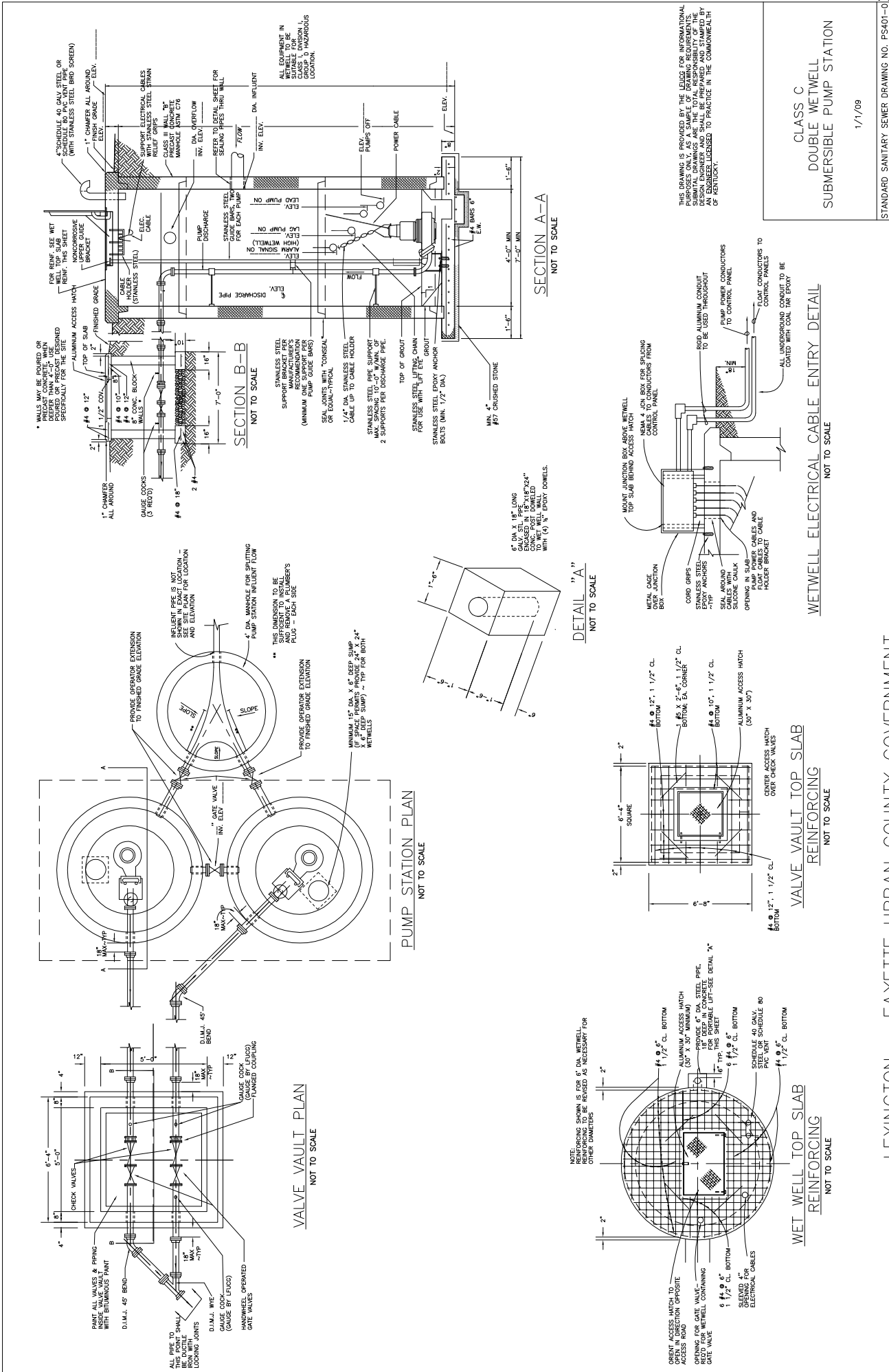

LEXINGTON - FAYETTE URBAN COUNTY GOVERNMENT

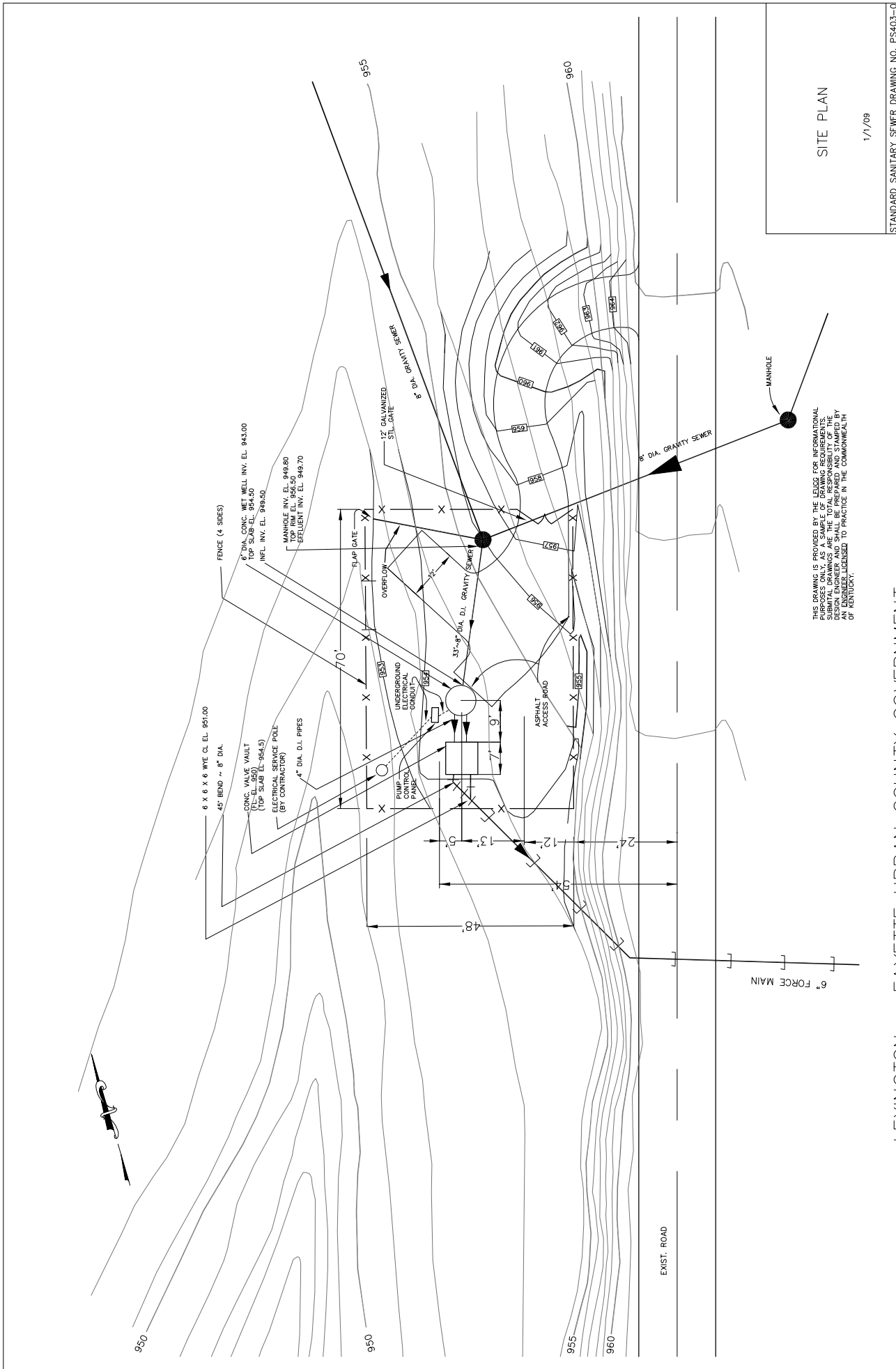

THIS DRAWING IS PROVIDED BY THE LEVISO FOR INFORMATIONAL PURPOSES ONLY. AS A SAMPLE OF DRAWING REQUIREMENTS, SUBMITTAL DRAWINGS ARE THE TOTAL RESPONSIBILITY OF THE SUBMITTER. THE SUBMITTER SHALL BE RESPONSIBLE FOR OBTAINING ALL NECESSARY PERMITS AND AN ENGINEER LICENSED TO PRACTICE IN THE COMMONWEALTH OF KENTUCKY.

SITE PLAN

1/1/09

STANDARD SANITARY SEWER DRAWING NO. PS403-0

LEXINGTON - FAYETTE URBAN COUNTY GOVERNMENT

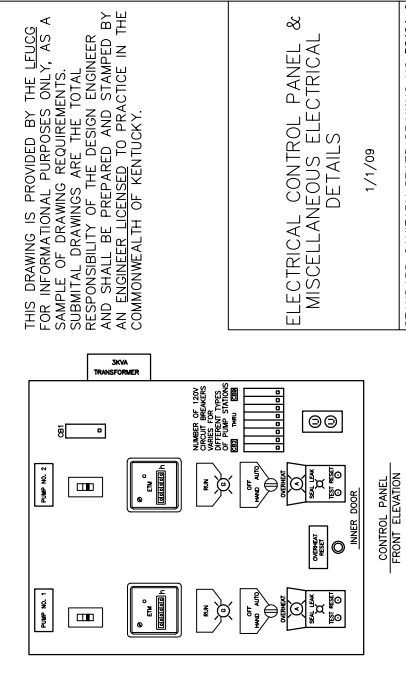
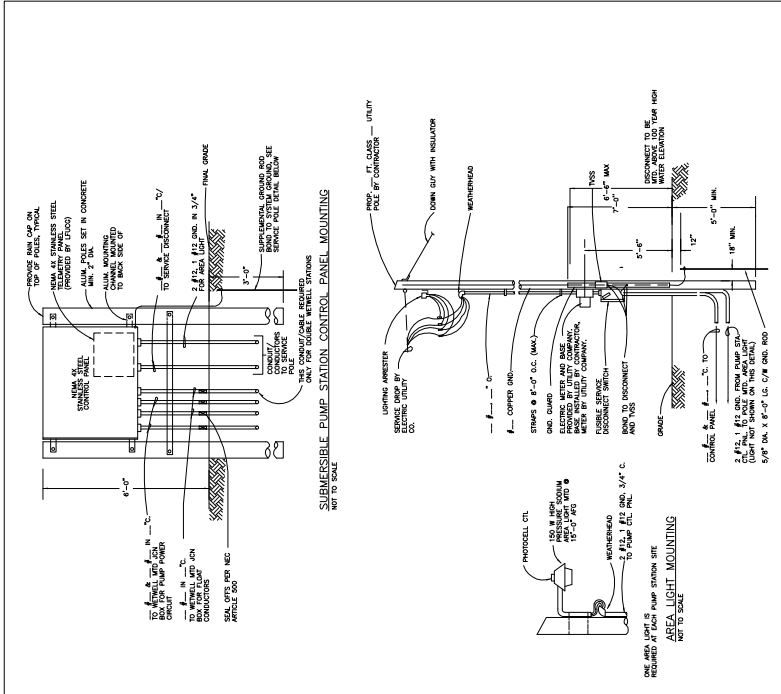
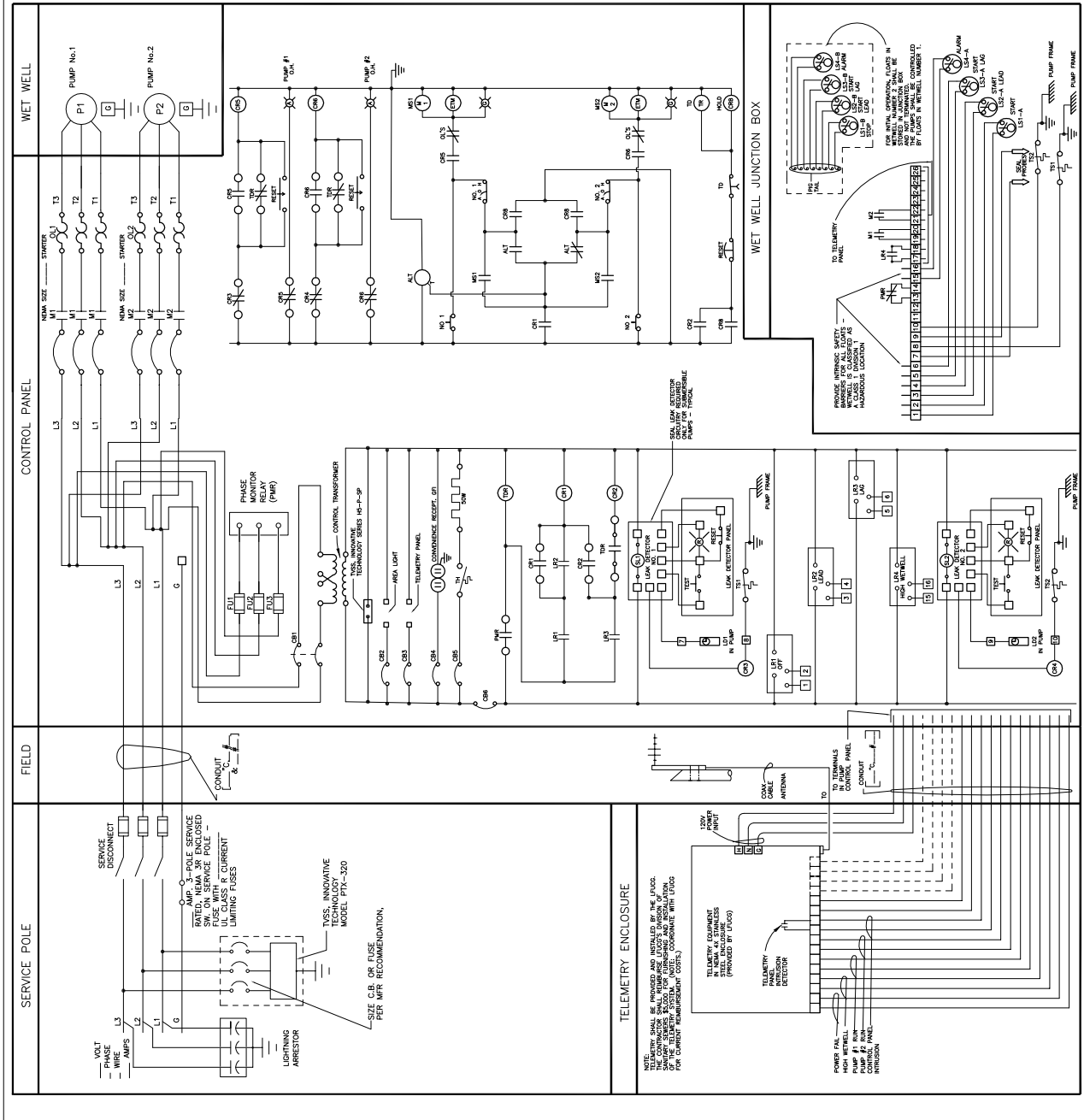

THIS DRAWING IS PROVIDED BY THE LEUCC FOR INFORMATIONAL PURPOSES ONLY, AS A SUPPLEMENT TO THE CONTRACT DOCUMENTS. THE RESPONSIBILITY OF THE DESIGN ENGINEER AND SHALL BE PREPARED AND STAMPED BY AN ENGINEER LICENSED TO PRACTICE IN THE COMMONWEALTH OF KENTUCKY.

ELECTRICAL CONTROL PANEL & MISCELLANEOUS ELECTRICAL DETAILS

1/1/09

STANDARD SANITARY SEWER DRAWING NO. FS404-0

* ALL PIPE AND FITTINGS TO BE BLOCKED SHALL BE WRAPPED TO PREVENT PERMANENT ENCASEMENT OF JOINTS.

45° BEND						
SIZE	D	4"	6"	8"	10"	12"
W		8"	8"	10"	12"	12"
L		14"	18"	20"	22"	27"
H		14"	16"	18"	20"	24"
T		13"	15"	16"	18"	18"

90° BEND						
SIZE	D	4"	6"	8"	10"	12"
W		8"	8"	10"	12"	12"
L		14"	24"	30"	35"	40"
H		14"	16"	18"	24"	30"
T		13"	16"	18"	20"	22"

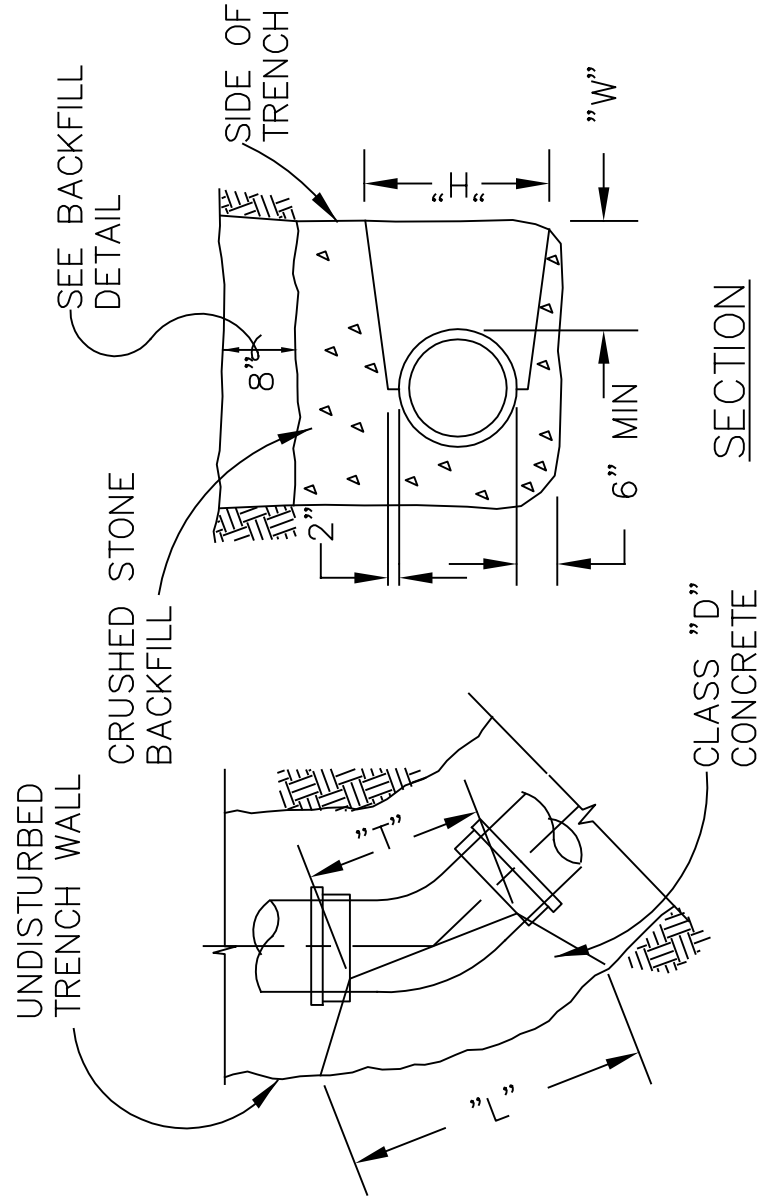

PLAN

SECTION

HORIZ. & VERT. BENDS &
CONCRETE BACKING

1/1/09

2" DIA. PVC VENT
CRUSHED STONE (NO. 57)
HALFWAY AROUND
MANHOLE

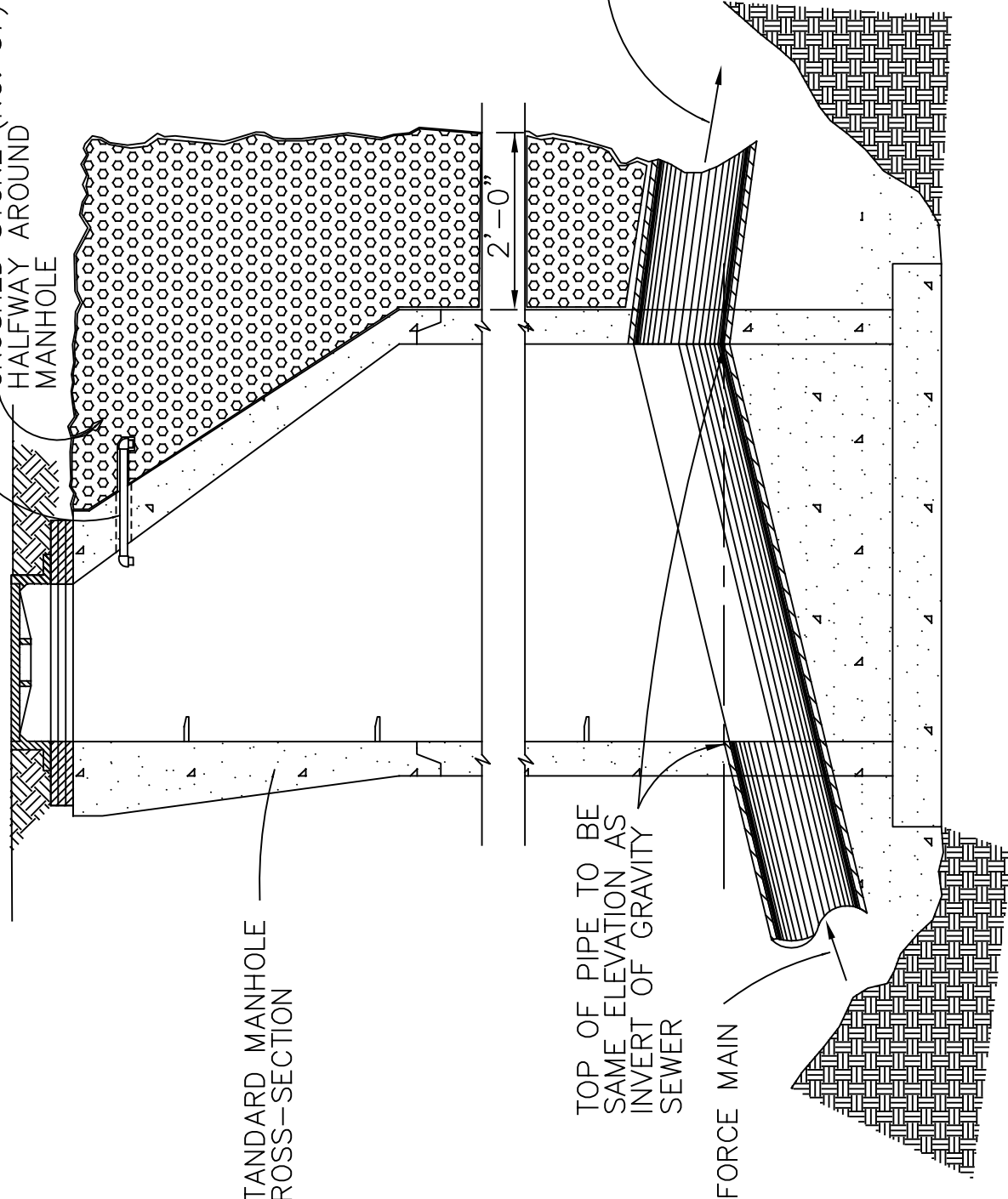

STANDARD MANHOLE
CROSS-SECTION

TOP OF PIPE TO BE
SAME ELEVATION AS
INVERT OF GRAVITY
SEWER

FORCE MAIN

GRAVITY SEWER

TYPICAL MANHOLE FOR
TRANSITION FROM FORCE MAIN
TO GRAVITY SEWER

1/1/09

STANDARD SANITARY SEWER DRAWING NO. PS407-0

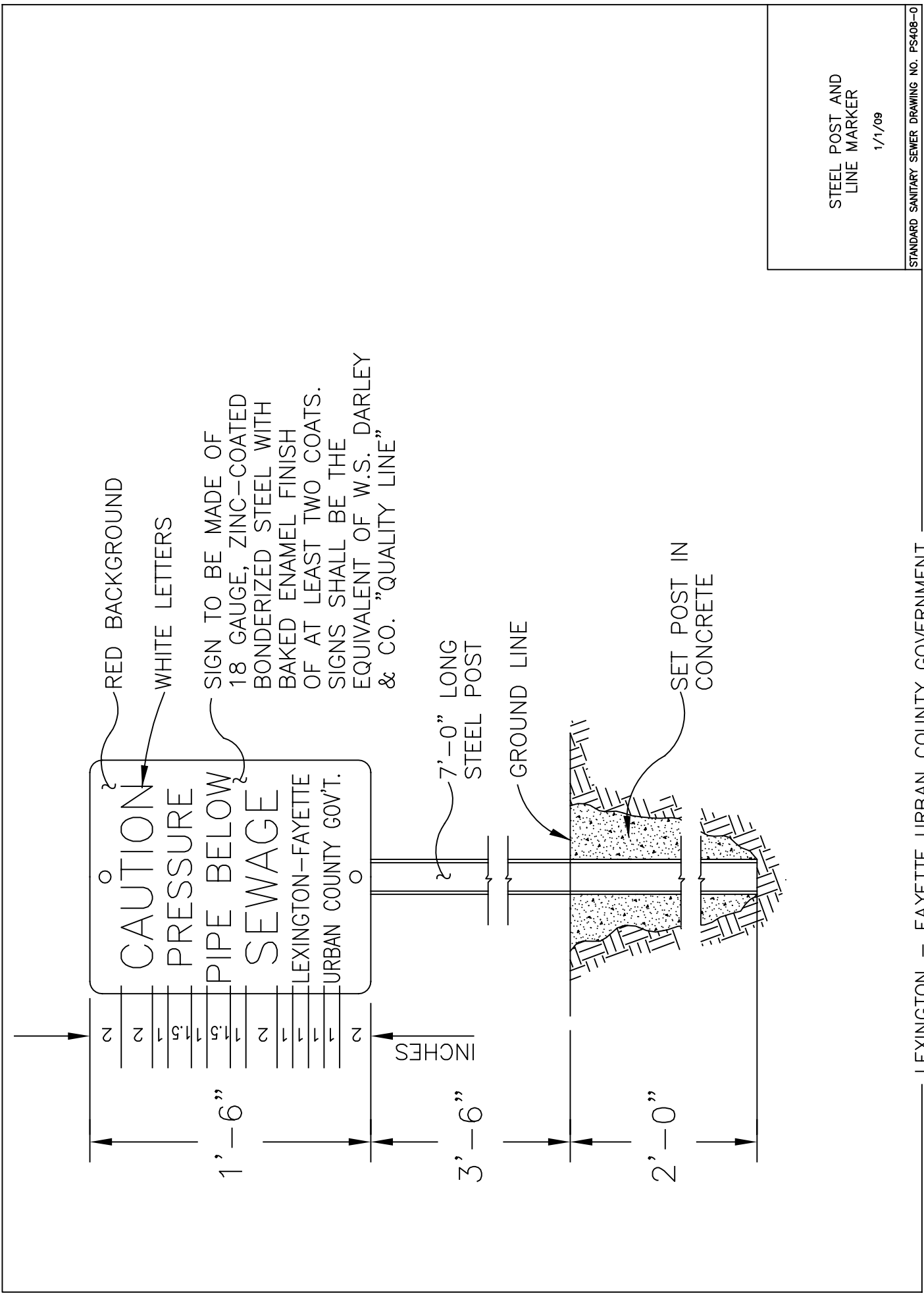

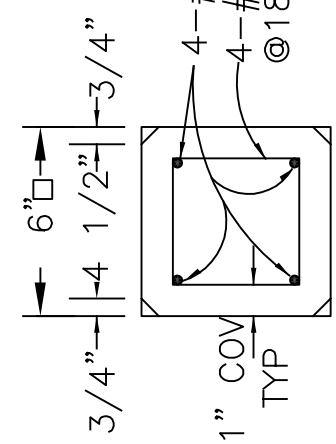
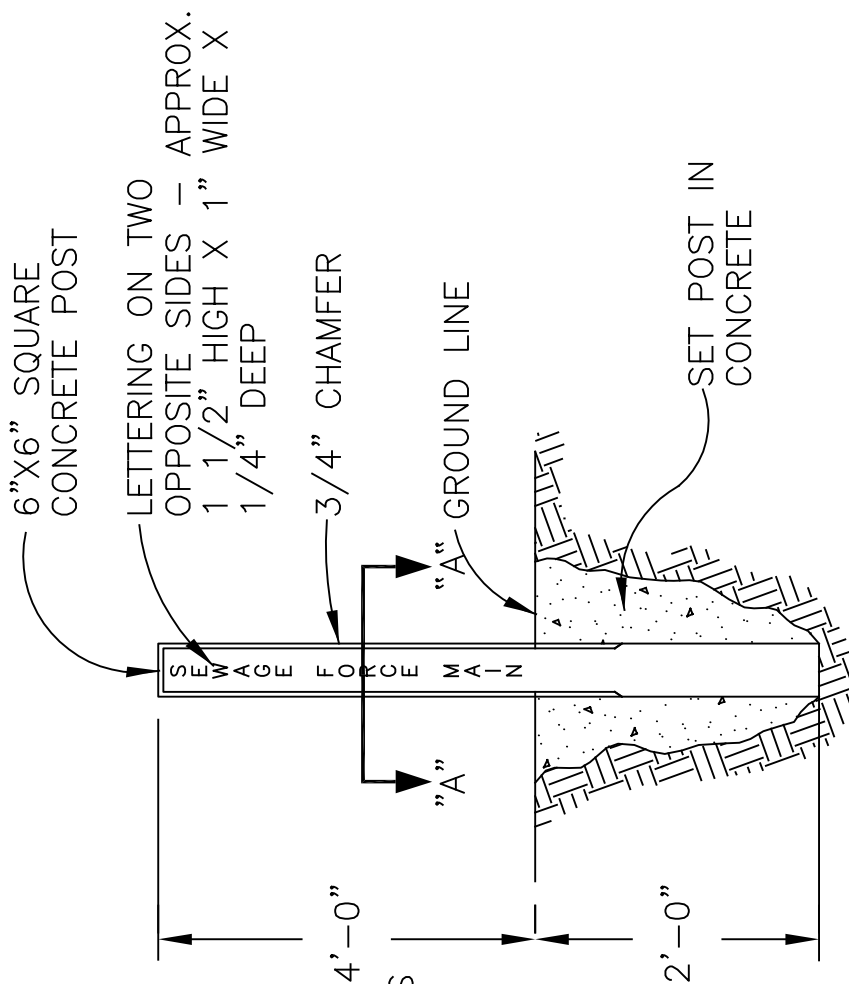

SECTION "A"

CONCRETE LINE MARKER

1/1/09

STANDARD SANITARY SEWER DRAWING NO. PS409-0

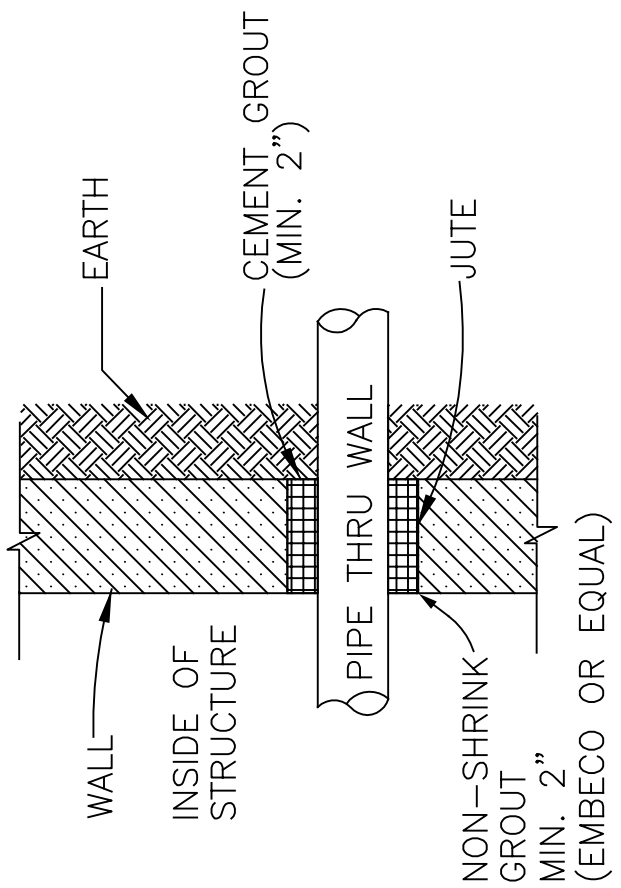
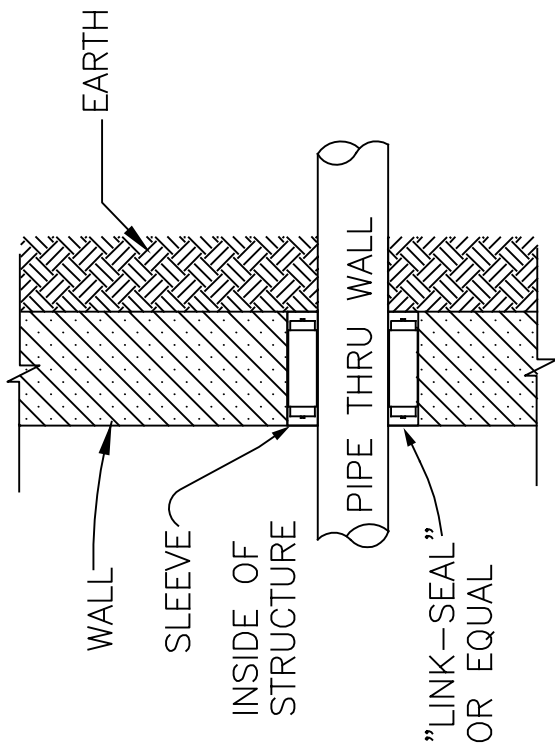

WALL PENETRATION DETAIL

1/1/09

STANDARD SANITARY SEWER DRAWING NO. PS410-0

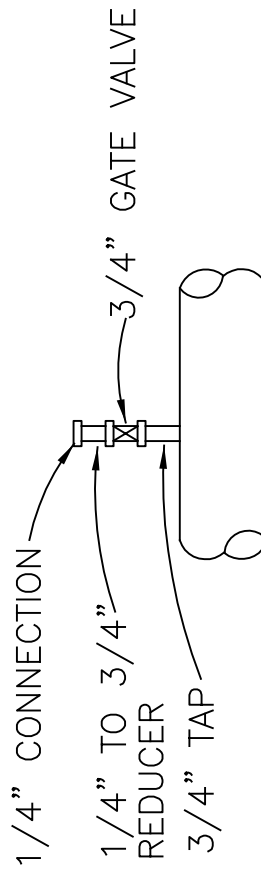

GAUGE TAP DETAIL

1/1/09

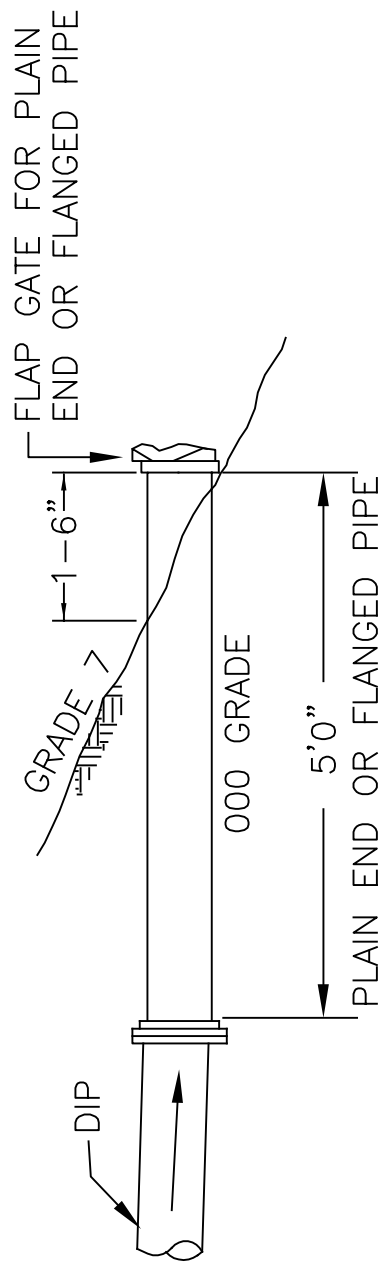

FLAP GATE INSTALLATION

1/1/09

STANDARD SANITARY SEWER DRAWING NO. PS412-0

LEXINGTON - FAYETTE URBAN COUNTY GOVERNMENT

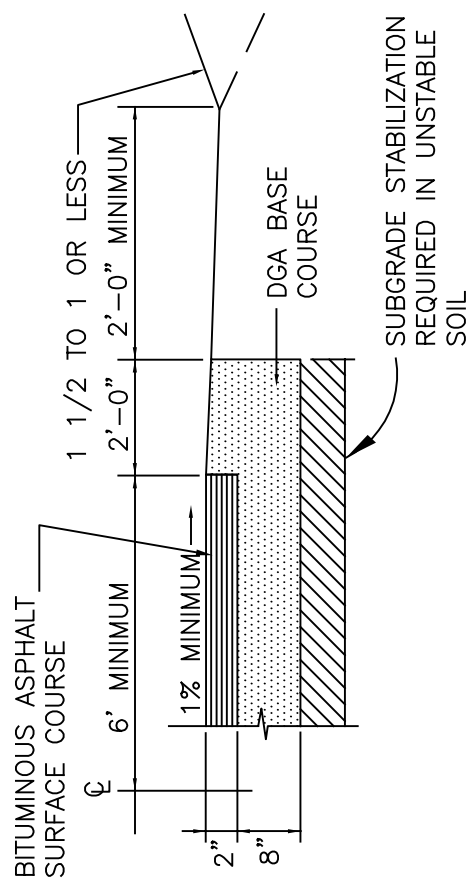

ASPHALT PUMP STATION
ACCESS ROAD

1/1/09

STANDARD SANITARY SEWER DRAWING NO. PS413-0

LEXINGTON - FAYETTE URBAN COUNTY GOVERNMENT

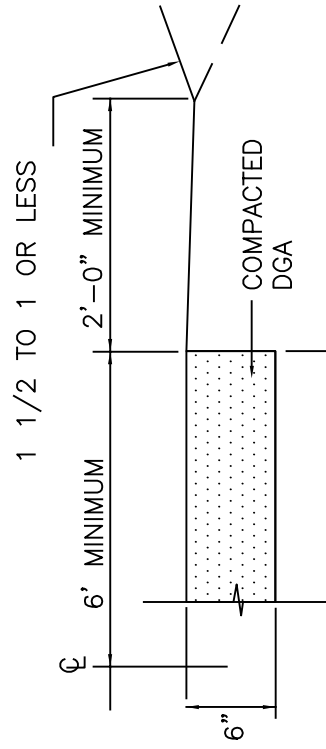

NOTE:
ASPHALT ACCESS ROAD REQUIRED
UNLESS DEVIATION APPROVED BY
LFUGG.

CRUSHED STONE
ACCESS ROAD

1/1/09

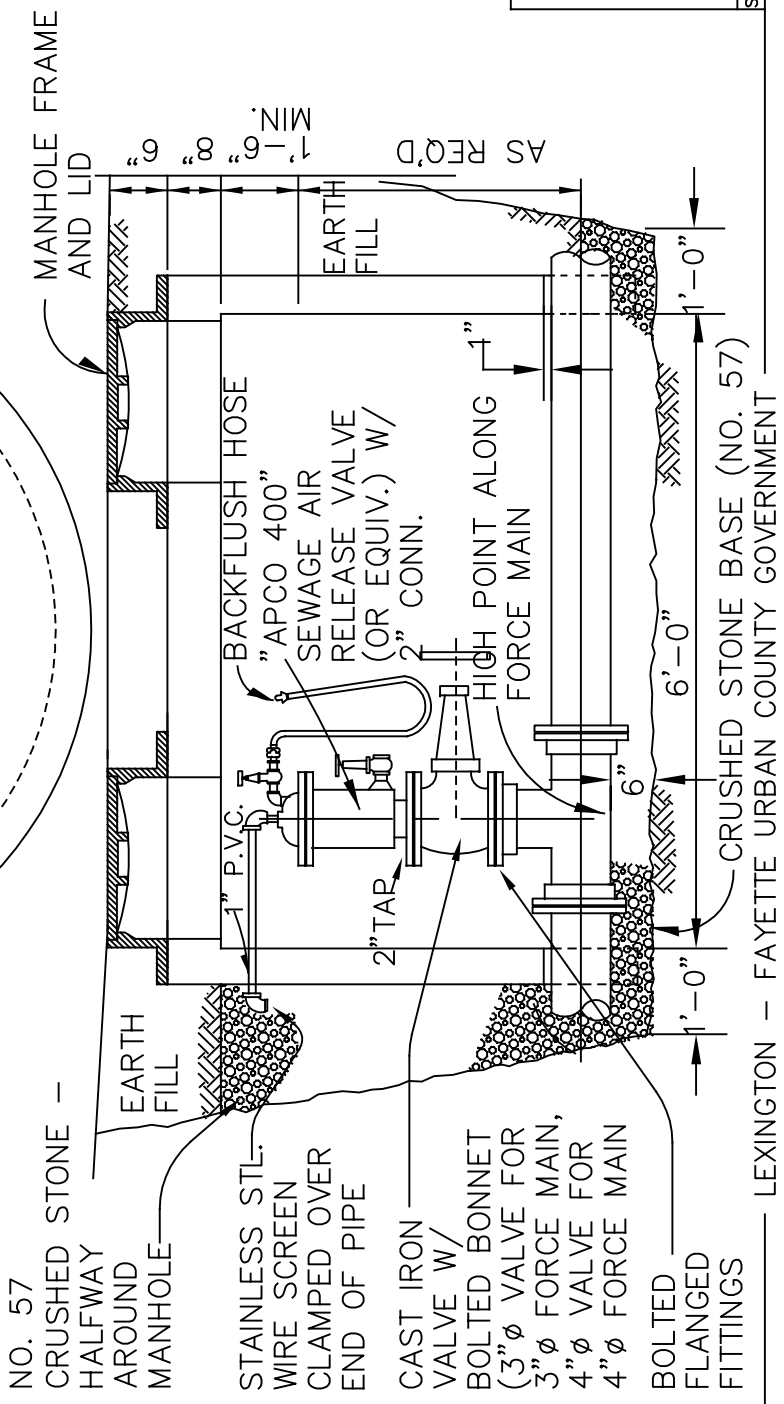
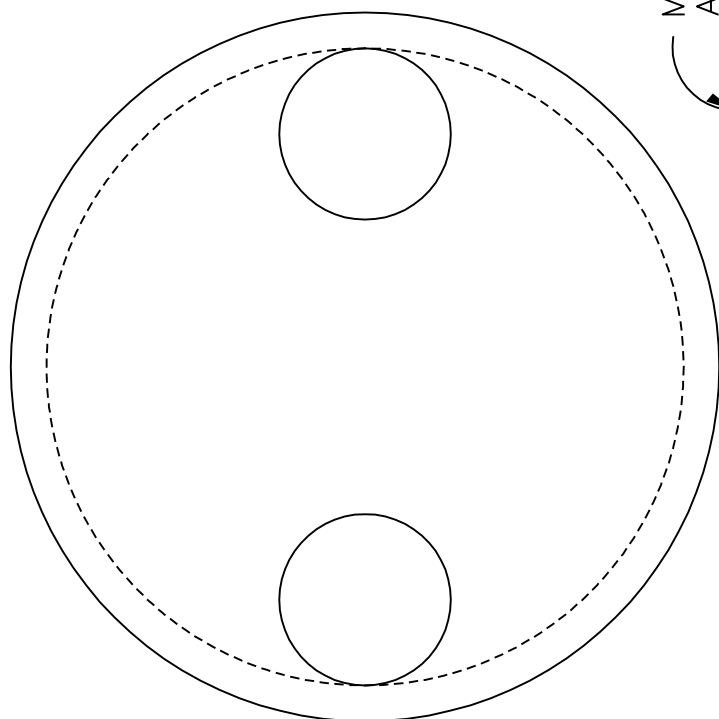

AUTOMATIC AIR
 RELEASE ASSEMBLY

1/1/09

STANDARD SANITARY SEWER DRAWING NO. PS415-0

- NO. 57
- CRUSHED STONE -
- HALFWAY
- AROUND
- MANHOLE
- EARTH FILL
- MANHOLE FRAME AND LID
- MIN. 1'-6"
- 8"
- AS REQ'D
- EARTH FILL
- BACKFLUSH HOSE
- "APCO 400"
- SEWAGE AIR
- RELEASE VALVE
- (OR EQUIV.) W/
- 2" CONN.
- HIGH POINT ALONG
- FORCE MAIN
- 6'-0"
- 1'-0"
- CRUSHED STONE BASE (NO. 57)
- 1'-0"
- 6"
- 1" P.V.C.
- 2" TAR
- CAST IRON
- VALVE W/
- BOLTED BONNET
- (3" ϕ VALVE FOR
- FORCE MAIN,
- 4" ϕ VALVE FOR
- FORCE MAIN
- BOLTED
- FLANGED
- FITTINGS

LEXINGTON - FAYETTE URBAN COUNTY GOVERNMENT

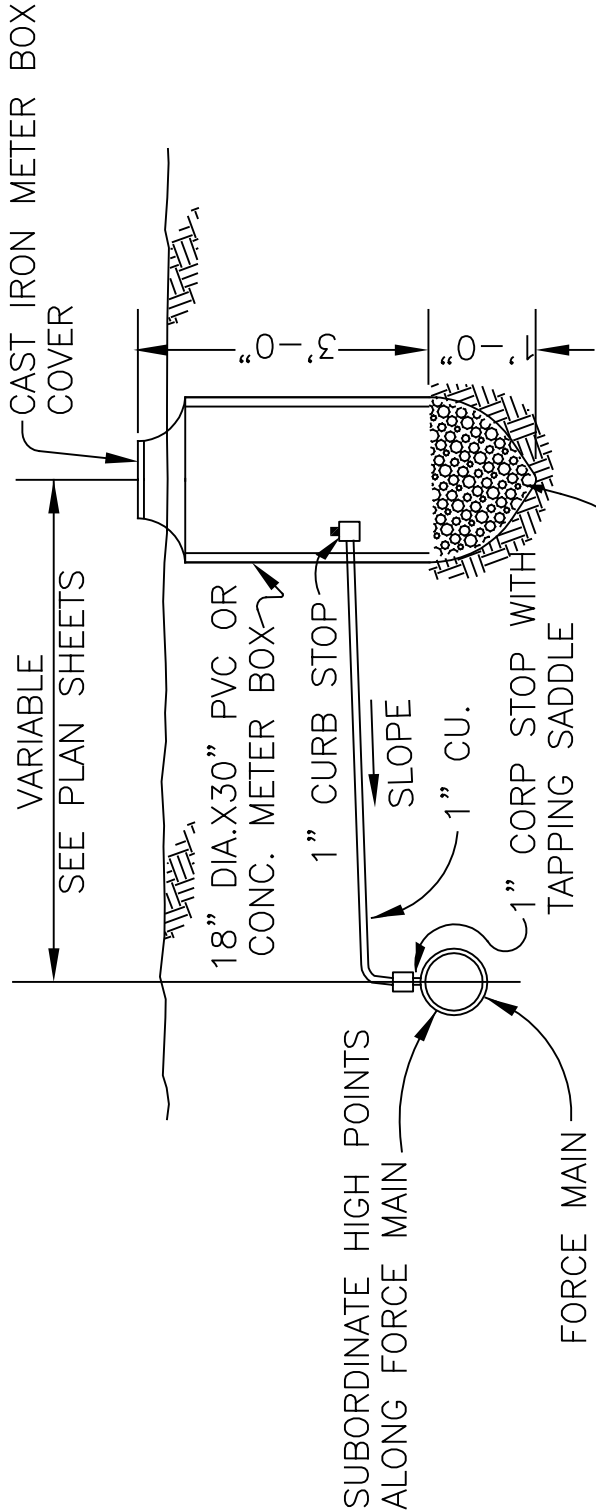

NO. 57 CRUSHED STONE FILL

MANUAL AIR RELEASE
ASSEMBLY

1/1/09

STANDARD SANITARY SEWER DRAWING NO. PS416-0

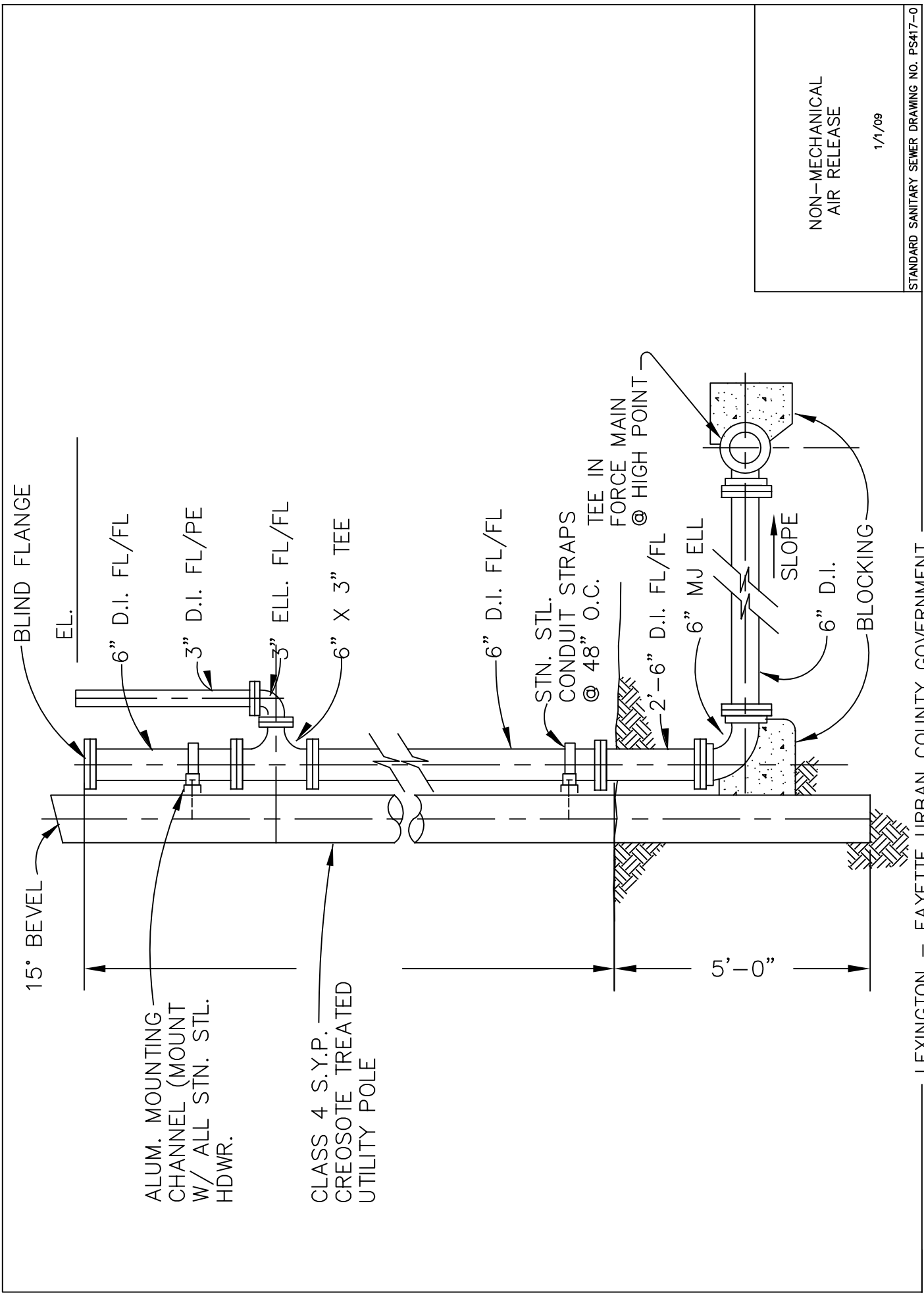

NON-MECHANICAL
AIR RELEASE

1/1/09

STANDARD SANITARY SEWER DRAWING NO. PS417-0

LEXINGTON - FAYETTE URBAN COUNTY GOVERNMENT

APPENDIX C – CONSTRUCTION SPECIFICATIONS

SECTION 02225

EXCAVATING, BACKFILLING, AND COMPACTING FOR SEWERS

PART 1 - GENERAL

1.01 SUMMARY

- A. Excavating of trenches.
- B. Bedding of pipe.
- C. Backfilling trenches.
- D. Installing Identification Tape.

PART 2 - PRODUCTS

2.01 BEDDING AND BACKFILLING STONE

- A. Crushed Stone material shall conform to the Kentucky Transportation Cabinet's Standard Specifications for Road and Bridge Construction, Current Edition, latest revision.
- B. Bedding Stone: No. 9 Crushed Stone.
- C. Backfill Stone: No. 9 Crushed Stone.

PART 3 - EXECUTION

3.01 GENERAL REQUIREMENTS

- A. Trenching may be accomplished by means of a backhoe, trenching machine or by hand depending on the construction area. At the Contractor's option, trenching by a trenching machine or by backhoe is acceptable except as noted below:
 - 1. Where the pipe line parallels a state highway and is being installed within the limits of the shoulder, a trenching machine must be used whenever practicable.
 - 2. Where the pipe line is being constructed close to other utilities, structures, building, or large trees, and it is reasonable to anticipate possible damage from the use of a backhoe, then trenching shall be made by hand methods.
- B. Clearing - All trees, stumps, bushes, shrubbery, and abandoned concrete or masonry structures within the limits of the trench shall be removed by the Contractor and disposed of in a manner satisfactory to the land owner and in accordance with federal, state, and local regulations. All clearing work shall be considered as incidental to the cost of laying pipe.
- C. Bracing and Sheeting - In areas of unstable soils, bracing and sheeting shall be provided to adequately protect the workers during pipe line installation.
 - 1. All requirements of the Occupational Safety and Health Act (OSHA) shall be met during trenching and backfill operations.

2. When sheeting and bracing are required, the trench width shall not be less than specified herein. As backfill is placed, the sheeting shall be withdrawn in increments not exceeding one (1) foot and the void left by the withdrawn sheeting shall be filled and compacted.
 3. The Engineer will not be responsible for determining requirements for bracing or sheeting.
- D. Excavated materials shall be piled in a manner that will not endanger the Work and will avoid obstructing driveways and sidewalks. Gutters shall be kept clear or other satisfactory provisions made for street drainage.

3.02 TRENCHING

A. General:

1. The Contractor shall perform all excavation of every description and of whatever substances encountered, including clearing over the pipe line route. All excavations for the pipe line shall be open-cut except at paved city and county roads, state and federal highways, railroads and blacktop or concrete driveways which shall be bored unless otherwise approved by Engineer. Banks of excavations shall be kept as nearly vertical as possible.
2. Trench widths at the top of the pipe shall not be less than or greater than that given in the following table:

ALLOWABLE TRENCH WIDTHS		
Pipe Diameter (inches)	Minimum Width (inches)	Maximum Width (inches)
4 & less	16	28
6	18	30
8	20	32
10	22	34
12	24	36
14	26	38
16	28	40
18	30	42
20	32	44

B. Trench Depth:

1. The trench shall be excavated to a depth sufficient to provide 48 inches of cover over the pipe. In addition, excavation shall be carried to a minimum of six (6) inches below pipe grade in rock.

C. Blasting for excavation will be permitted only when proper precautions are taken for the protection of persons and property. Any damage caused by the blasting shall be repaired by the Contractor at his expense. The Contractor's methods of blasting and procedure shall conform to federal, state, and local laws and municipal ordinances. The Engineer will not be responsible, nor direct in any way, blasting practices of the Contractor.

3.03 FORCE MAIN BEDDING

- A. Refer to LFUCG Standard Drawings.
- B. The trench shall be excavated to a depth to allow a minimum of 48 inches cover over the top of the pipe.
- C. When the subgrade is found to be unstable or to include ashes, cinders, refuse, organic material, or other unsuitable material, such material shall be removed to the depth ordered by the Engineer and replaced under the directions of the Engineer with clean, stable backfill material. When the bottom of the trench or the subgrade is found to consist of material that is unstable to such a degree that, in the judgment of the Engineer it cannot be removed, a foundation for the pipe and/or appurtenance shall be constructed using piling, concrete, or other materials at the direction of the Engineer.

3.04 FORCE MAIN BACKFILLING

- A. Refer to LFUCG Standard Drawings

3.05 GRAVITY SEWER PIPE BEDDING

- A. Refer to LFUCG Standard Drawings.
- B. When the subgrade is found to be unstable or to include ashes, cinders, refuse, organic material, or other unsuitable material, such material shall be removed to the depth ordered by the Engineer and replaced under the directions of the Engineer with clean, stable backfill material. When the bottom of the trench or the subgrade is found to consist of material that is unstable to such a degree that, in the judgement of the Engineer it cannot be removed, a foundation for the pipe and/or appurtenance shall be constructed using piling, concrete, or other materials at the direction of the Engineer.

3.06 GRAVITY SEWER PIPE BACKFILLING

- A. Refer to LFUCG Standard Drawings.
 - 1. Final backfill beneath existing driveways, and beneath existing and proposed roads, shall be No. 9 Crushed Stone up to the subgrade of vehicular traffic surface courses. This does not apply to driveways in subdivisions under construction, because the location of driveways is unknown at the time the sewer is constructed.

3.07 INSTALLING IDENTIFICATION TAPE

- A. Detectable underground marking tape shall be installed over all utility lines. Care shall be taken to insure that the buried marking tape is not broken when installed and shall be Lineguard brand encased aluminum foil, Type III. The identification tape is manufactured by Lineguard, Inc., P.O. Box 426, Wheaton, IL 60187.
- B. The identification tape shall bear the printed identification of the plastic utility line below it, such as "Caution - Buried Below." Tape shall be reverse printed; surface printing will not be acceptable. The tape shall be visible in all types and colors of soil and provide maximum color contrast to the soil. The tape shall meet the APWA color code, and shall be two (2) inches in width. Colors are green for sewer and brown for force main.

- END OF SECTION -

SECTION 02608

MANHOLES

PART 1 - GENERAL

1.01 SUMMARY

The Contractor shall furnish all labor, material, and equipment necessary to construct manholes for sanitary and/or storm sewers, including steps, frames, and covers, together with all appurtenances as shown and detailed on the Drawings and specified herein. Manhole materials shall be precast concrete.

1.02 DEFINITIONS

- A. Standard Manhole: A standard manhole is defined as any manhole that is greater than 5 feet in depth, as measured from the invert of the manhole base at its center to the top (rim) of the manhole cover.
- B. Shallow Manhole: A shallow manhole is defined as any manhole that is 5 feet or less in depth, as measured in the preceding sentence.

PART 2 - PRODUCTS

2.01 CONCRETE MANHOLES - GENERAL

- A. Manholes shall conform in shape, size, dimensions, materials, and other respects as shown on the Drawings or specified herein.
- B. All concrete manholes shall have precast reinforced concrete developed bases. No other type of base will be allowed. Invert channels shall be factory constructed when the base is made. Sloping invert channels shall be constructed whenever the difference between the inlet and outlet elevation is 2 feet or less.
- C. The concrete manhole walls (barrels and cones) shall be precast concrete sections. The top of the cone shall be built of reinforced concrete adjustment rings to permit adjustment of the frame to meet the finished surface. Minimum strength of the concrete for the precast sections shall be 4,000 psi at the time of shipment.
- D. For concrete manholes, the inverts of the developed bases shall conform accurately to the size of the adjoining pipes. Side inverts shall be curved and main inverts (where direction changes) shall be laid out in smooth curves of the longest possible radius which is tangent, within the manhole, to the centerlines of adjoining pipelines.
- E. For concrete manholes, the cast iron frames and covers shall be the standard frame and cover as indicated on the Drawings and specified herein.
- F. Manholes shall be manufactured by Kentucky Precast, or approved equal.

2.02 PRECAST CONCRETE SECTIONS

- A. Precast concrete sections and appurtenances shall conform to the ASTM Standard Specifications for Precast Reinforced Concrete Manhole Sections, Designation C478, latest revision, with the following exceptions and additional requirements.

- B. The base section shall be monolithic for 4-foot diameter manholes. Manholes with diameter of 5 feet or larger shall have base slab.
- C. The wall sections shall be not less than 5 inches thick.
- D. Type II cement shall be used except as otherwise permitted.

2.03 CONCRETE MANHOLE - FRAMES AND COVERS

- A. The Contractor shall furnish all cast iron manhole frames and covers conforming to the Drawings or as specified herein.
- B. The castings shall be of good quality, strong, tough, evengrained cast iron, smooth, free from scale, lumps, blisters, sandholes, and defects of every nature which would render them unfit for the service for which they are intended. Contact surfaces of covers and frame seats shall be machined to prevent rocking of covers.
- C. All casting shall be thoroughly cleaned and subject to a careful hammer inspection.
- D. Castings shall be at least Class 25 conforming to the ASTM Standard Specifications for Gray Iron Casting, Designation A48, latest revision.
- E. Unless otherwise specified, manhole covers shall be 22-3/4 inches in diameter, weighing not less than 350 pounds per frame and cover. Manhole covers shall set neatly in the rings, with contact edges machined for even bearings and tops flush with ring edge. They shall have sufficient corrugations to prevent slipperiness. The covers shall have two (2) pick holes about 1-1/4 inches wide and 1/2 inch deep with 3/8-inch undercut all around. Covers shall not be perforated. Frames and covers shall be J.R. Hoe and Sons, Mc-350, or approved equal.
- F. All covers shall be marked in large letters "SANITARY SEWER".

2.04 MANHOLE STEPS (CONCRETE MANHOLES)

Manholes steps shall be the polypropylene plastic type reinforced with a 1/2 inch diameter deformed steel rod. The step shall be 10-3/4 inches wide and extend 5-3/4 inches from the manhole wall. Steps shall line up over the downstream invert of the manhole. The steps shall be embedded into the manhole wall a minimum of 3-3/8 inches. Steps shall be uniformly spaced at 12-inch to 16-inch intervals.

2.05 PREMOLDED ELASTOMERIC-SEALED JOINTS

All holes for pipe connections in concrete barrels and bases shall have a factory-installed flexible rubber gasket to prevent infiltration. The manhole boots shall conform to the latest revision of ASTM-C923. The boots shall be Contour Seal or Kor-N-Seal manufactured by National Pollution Control Systems, Inc., Nashua, NH; A-Lok Manhole Pipe Seal manufactured by A-Lok Corporation, Trenton, NJ; or an approved equal.

2.06 POLYETHYLENE DIAPHRAGM

- A. Polyethylene diaphragm manhole inserts shall be manufactured from corrosion-proof material suitable for atmospheres containing hydrogen sulfide and diluted sulfuric acid. Diaphragm shall be installed in manholes susceptible to inflow as indicated on the Drawings.

- B. The body of the manhole insert shall be made of high density polyethylene copolymer material meeting ASTM Specification D 1248, Class A, Category 5, Type III (the insert shall have a minimum impact brittleness temperature of -180 degrees Fahrenheit). The thickness shall be uniform 1/8 inch or greater. The manhole insert shall be manufactured to dimensions as shown on the Drawings to allow easy installation within the manhole frame.
- C. Gaskets shall be made of closed cell neoprene. The gasket shall have a pressure sensitive adhesive on one side and shall be placed under the weight bearing surface of the insert by the manufacturer. The adhesive shall be compatible with the manhole insert material so as to form a long lasting bond in either wet or dry conditions.
- D. Lift strap shall be attached to the rising edge of the bowl insert. The lift strap shall be made of 1 inch wide woven polypropylene web and shall be seared on all cut ends to prevent unraveling. The lift strap shall be attached to the manhole insert by means of a stainless steel rivet. Location of the lift strap shall provide easy visual location.
- E. Standard ventilation shall be by means of a valve or vent hole. Vent holes shall be on the side wall of the manhole insert approximately 3/4 inch below the lip. The valve or vent hole will allow a maximum release of 10 gallons per 24 hours when the insert is full.
- F. The manhole insert shall be manufactured to fit the manhole frame rim upon which the manhole cover rests. The Contractor is responsible for obtaining specific measurements of each manhole cover to insure a proper fit. The manhole frame shall be cleaned of all dirt, scale and debris before placing the manhole insert on the rim.

2.07 CLEANOUTS

Cleanouts shall be cast iron and extend to the finish grade and capped with a clean-out plug in accordance with details and at locations shown on the Drawings. Pipe shall be the same size as the gravity sewer line in which the cleanout is located. A 4-inch thick concrete pad, with 6" x 6", 1.9 x 1.9 wire mesh, 24 inches square, with the valve box lid section, shall be provided around each cleanout.

2.08 DROP CONNECTIONS

Drop connections shall be installed in the manhole as shown on the Drawings. The pipe material inside the drop manhole shall be of the same material as the sanitary sewer line. Any deviation from the standard drawing shall be approved by the Division of Engineering and the Division of Water Quality.

PART 3 - EXECUTION

3.01 FABRICATION - PRECAST SECTIONS

- A. Manhole sections shall contain manhole steps accurately positioned and embedded in the concrete when the section is cast.
- B. Sections shall be cured in an enclosed curing area and shall attain a strength of 4,000 psi prior to shipment.
- C. Knuckle hooks are preferred.
- D. Flat slab tops shall have a minimum thickness of 6 inches and reinforcement in accordance with ASTM C478.

- E. The date of manufacture and the name or trademark of the manufacturer shall be clearly marked on the precast sections.
- F. Acceptance of the sections will be on the basis of material tests and inspection of the completed product and test cylinders if requested by the Engineer.
- G. Cones shall be precast sections of similar construction.

3.02 SETTING PRECAST MANHOLE SECTIONS

- A. Refer to Standard Drawings.
- B. Precast-reinforced concrete manhole sections shall be set so as to be vertical and with sections and steps in true alignment.
- C. All holes in sections used for their handling shall be thoroughly plugged with rubber plugs made specifically for this purpose.

3.03 ADJUSTING MANHOLE FRAMES AND COVERS TO GRADE

- A. Except where shown on the Drawings, the top of the precast concrete eccentric cone of a standard manhole or the top of the flat slab of a shallow manhole shall terminate 4 inches below existing grade in an unpaved non-traffic area except in a residential yard and 13 inches below existing grade in a paved or unpaved traffic area and in a residential yard. The remainder of the manhole shall be adjusted to the required grade as described hereinafter in paragraphs B and C of this article.
- B. When a manhole is located in an unpaved non-traffic area other than in a residential yard, the frame and cover shall be adjusted to an elevation 3 inches to 5 inches above the existing grade at the center of the cover. If field changes have resulted in the installed manhole invert elevation to be lower than the invert elevation shown on the Drawings, the adjustment to an elevation of 3 inches to 5 inches above existing grade shall be accomplished by the use of precast concrete adjusting rings. If field changes have resulted in the completed manhole invert to be greater than the invert shown on the Drawings and the cover higher than 5 inches above existing grade, then the top of the eccentric cone, when used, or the top of the barrel section, when used, shall be trimmed down so that the manhole cover, after installation, is no greater than 5 inches above existing grade at the center of the cover. The area around the adjusted frame and cover shall be filled with the required material, sloping it away from the cover at a grade of 1 inch per foot.
- C. When a manhole is located in a bituminous, concrete, or crushed stone traffic area, or in a residential yard, the frame and cover shall be adjusted to the grade of the surrounding area by the use of precast concrete adjusting rings. The adjusted cover shall conform to the elevation and slope of the surrounding area. If field changes have resulted in the installed manhole invert elevation to be so much higher than the invert elevation shown on the Drawings that the top of the eccentric cone, when used, or the top of the flat slab, when used, is less than the thickness of the frame and cover 7 inches from the grade of the surrounding area, then the top of the cone or barrel section shall be trimmed down enough to permit the cover, after installation, to conform to the elevation and slope of the surrounding area. After installation, the inside and outside surfaces shall receive a waterproofing bitumastic coating.
 - 1. The Contractor shall coordinate elevations of manhole covers in paved streets with the LFUCG. If resurfacing of the street in which sewers are laid is expected within

twelve (12) months, covers shall be set 1-1/2 inches above the existing pavement surface in anticipation of the resurfacing operations.

3.04 ADJUSTING SECTIONS

Only clean adjusting sections shall be used. Each adjusting section shall be laid in a bead of butyl mastic sealant and shall be thoroughly bonded.

3.05 SETTING MANHOLE FRAMES AND COVERS

- A. Manhole frames shall be set with the tops conforming to the required elevations set forth hereinbefore. Frames shall be set concentric with the top of the concrete and in a full bead of butyl mastic sealant so that the space between the top of the masonry and the bottom flange of the frame shall be completely watertight.
- B. Manhole covers shall be left in place in the frames on completion of other work at the manholes.

3.06 VACUUM TESTING (ASTM C1244)

A. Scope

- 1. This test method covers procedures for testing precast concrete manhole sections when using the vacuum test method to demonstrate the integrity of the installed materials and the construction procedures. This test method is used for testing concrete manhole sections utilizing mortar or mastic joints.
- 2. This test method is intended to be used as a preliminary test to enable the installer to demonstrate the condition of the concrete manholes prior to backfill. It may also be used to test manholes after backfilling; however, testing should be correlated with the connector supplier.
- 3. This standard does not purport to address all of the safety problems, if any, associated with its use. It is the responsibility of the user of this standard to establish appropriate safety and health practices and determine the applicability of regulatory limitations prior to use.
- 4. This test method is the companion to metric Test Method C 1244M; therefore, no SI equivalents are shown in this test method.

B. References, ASTM Standards:

- 1. C 822 Terminology Relating to Concrete Pipe and Related Products.
- 2. C 924 Practice for Testing Concrete Pipe Sewer Lines by Low-Pressure Air Test Method.
- 3. C 969 Practice for Infiltration and Exfiltration Acceptance Testing of Installed Precast Concrete Pipe Sewer Lines.

C. Terminology

For definitions of terms relating to manholes, see Terminology C 822.

D. Summary of Practice

All lift holes and any pipes entering the manhole are to be plugged. A vacuum will be drawn and the vacuum drop over a specified time period is used to determine the acceptability of the manhole.

E. Significance and Use

This is not a routine test. The values recorded are applicable only to the manhole being tested and at the time of testing.

F. Preparation of the Manhole

1. All lift holes shall be plugged.
2. All pipes entering the manhole shall be temporarily plugged, taking care to securely brace the pipes and plugs to prevent them from being drawn into the manhole.

G. Procedure

1. The test head shall be placed at the top of the manhole in accordance with the manufacturer's recommendations.
2. A vacuum of 10 inches of mercury shall be drawn on the manhole, the valve on the vacuum line of the test head closed, and the vacuum pump shut off. The time shall be measured for the vacuum to drop to 9 inches of mercury.
3. The manhole shall pass if the time for the vacuum reading to drop from 10 inches of mercury to 9 inches of mercury meets or exceeds the values indicated in the table below.
4. Vacuum test time shall be a minimum of one minute.

Minimum Test Times for Various Manhole Diameters (seconds)									
Depth (ft)	Diameter (inches)								
	30	33	36	42	48	54	60	66	72
1	1	2	2	2	2	3	3	4	4
2	3	3	4	4	5	6	7	7	8
3	4	5	5	6	7	9	10	11	12
4	6	6	7	9	10	12	13	15	16
5	7	8	9	11	12	14	16	18	20
6	8	10	11	13	15	17	20	22	24
7	10	11	12	15	17	20	23	26	28
8	11	12	14	17	20	23	26	29	33
10	14	15	18	21	25	29	33	36	41
12	17	18	21	25	30	35	39	43	49
14	20	21	25	30	35	41	46	51	57
16	22	24	28	34	40	46	52	58	67
18	25	27	32	38	45	52	59	65	73
20	28	30	35	42	50	58	65	72	81
22	31	33	39	46	55	64	72	79	89
24	33	36	42	51	59	69	78	87	97
26	36	39	46	55	64	75	85	94	105
28	39	42	49	59	69	81	91	101	113
30	42	45	53	63	74	87	98	108	121

4. If the manhole fails the initial test, necessary repairs shall be made by an approved method. The manhole shall then be retested until a satisfactory test is obtained.
5. Use or failure of this vacuum test shall not preclude acceptance by appropriate water infiltration or exfiltration testing, (see Practice C 969), or other means.

H. Precision and Bias

No justifiable statement can be made either on the precision or bias of this procedure, since the test result merely states whether there is conformance to the criteria for the success specified.

- END OF SECTION -

SECTION 02732

SEWAGE COLLECTION LINES

PART 1 - GENERAL

1.01 SUMMARY

The Contractor shall furnish all labor, material, and equipment necessary to install gravity sewer piping together with all appurtenances as shown and detailed on the Drawings and specified herein.

PART 2 – PRODUCTS

2.01 PIPE AND FITTINGS

- A. Ductile Iron (DI) Pipe:
- B. Scope: This article covers the design and manufacture of ductile iron centrifugally cast on metal molds and ductile iron fittings.

Specific Requirements: Ductile iron pipe shall be furnished cement lined unless otherwise noted on the drawings or in other sections of these specifications. Ductile iron pipe shall be furnished with rubber gasket push-on joints except as may otherwise be noted on the drawings or in difficult working areas and with approval of the Engineer.

1. Pressure class shall be 250 psi for pipe sizes 20 inches or smaller and pressure class 200 psi for pipe sizes larger than 20 inches for mechanical and push-on joint pipe.
2. Thickness design of ductile iron shall conform in all aspects to the requirements of ANSI/AWWA C150/A 21.50 latest revision.
3. Manufacture and testing of ductile iron pipe shall conform in all aspects to the requirements of ANSI/AWWA C151/A 21.51 latest revisions .
4. Pipe Coatings
 - a. Interior Lining

(1) Condition of Ductile Iron Prior to Surface Preparation

All ductile pipe and fittings shall be delivered to the application facility without asphalt, cement lining, or any other lining on the interior surface. Because removal of old linings may not be possible, the intent of this specification is that the entire interior of the ductile iron pipe and fittings shall not have been lined with any substance prior to the application of the specified lining material and no coating shall have been applied to the first six (6) inches of the exterior of the spigot ends.

(2) Lining Material

The standard of quality is Protecto 401 Ceramic Epoxy. The material shall be an amine cured novalac epoxy containing at least 20% by volume of ceramic quartz pigment. Any request for substitution must be accompanied by a successful history of lining pipe and fittings for sewer service, a test report verifying the following properties, and a certification of the test results.

- (a) A permeability rating of 0.00 when tested according to Method A of ASTM E-96-66, Procedure A with a test duration of 30 days.
- (b) The following test must be run on coupons from factory lined ductile iron pipe:
 - (b1) ASTM B-117 Salt Spray (scribed panel) – Results to equal 0.0 undercutting after two years.
 - (b2) ASTM G-95 Cathodic Disbondment 1.5 volts @ 77°F. Results to equal no more than 0.5mm undercutting after 30 days.
 - (b3) Immersion Testing rated using ASTM D-714-87.
 - 20% Sulfuric Acid – No effect after two years.
 - 25% Sodium Hydroxide – No effect after two years.
 - 160°F Distilled Water – No effect after two years.
 - 120°F Tap Water (scribed panel) – 0.0 undercutting after two years with no effect.
- (c) An abrasion resistance of no more than 4 mils (.10mm) loss after one million cycles – European Standard EN 598: 1994 section 7.8 Abrasion resistance.

(3) Application

(a) Applicator

The lining shall be applied by a competent firm with a successful history of applying linings to the interior of ductile iron pipe and fittings.

(b) Surface Preparation

Prior to abrasive blasting, the entire area to receive the protective compound shall be inspected for oil, grease, etc. Any areas where oil, grease, or any substance which can be removed by solvent is present, shall be solvent cleaned using the guidelines outlined in DIPRA-1 Solvent Cleaning. After the surface has been made free of grease, oil, or other substances, all areas to receive the protective compounds shall be abrasively blasted using compressed air nozzles with sand or grit abrasive media. The entire surface to be lined shall be struck with the blast media so that all rust, loose oxides, etc., are removed from the surface. Only slight stains and tightly adhering annealing oxide may be left on the surface. Any area where rust reappears before lining must be reblasted.

(c) Lining

After the surface preparation and within eight (8) hours of surface preparation, the interior of the pipe shall receive 40 mils nominal dry film thickness of Protecto 401. No lining shall take place when the substrate or ambient temperature is below 40 degrees Fahrenheit. The surface also must be dry and dust free. If flange pipe or fittings are included in the project, the lining shall not be used on the face of the flange.

(d) Coating of Bell Sockets and Spigot Ends

Due to the tolerances involved, the gasket area and spigot end up to six (6) inches back from the end of the spigot end must be coated with 6 mils nominal, 10 mils maximum Protecto Joint Compound. The Joint Compound shall be applied by brush to ensure coverage. Care should be taken that the Joint Compound is smooth without excess buildup in the gasket seat or on the spigot ends. Coating of the gasket seat and spigot ends shall be done after the application of the lining.

(e) Number of Coats

The number of coats of lining material applied shall be as recommended by the lining manufacturer. However, in no case shall this material be applied above the dry thickness per coat recommended by the lining manufacturer in printed literature. The maximum or minimum time between coats shall be that time recommended by the lining material manufacturer. **No material shall be used**

for lining which is not indefinitely recoatable with itself without roughening of the surface.

(f) Touch-Up and Repair

Protecto Joint Compound shall be used for touch-up or repair in accordance with manufacturer's recommendations.

(4) Inspection and Certification

(a) Inspection

(a1) All ductile iron pipe and fitting linings shall be checked for thickness using a magnetic film thickness gauge. The thickness testing shall be done using the method outlined in SSPC-PA-2 Film Thickness Rating.

(a2) The interior lining of all pipe barrels and fittings shall be tested for pinholes with a non-destructive 2,500-volt test. Any defects found shall be repaired prior to shipment.

(a3) Each pipe joint and fitting shall be marked with the date of application of the lining system along with its numerical sequence of application on that date and records maintained by the applicator of his work.

(b) Certification

The pipe or fitting manufacturer must supply a certificate attesting to the fact that the applicator met the requirements of this specification, and that the material used was as specified.

(5) Handling

Protecto 401 lined pipe and fittings must be handled only from the outside of the pipe and fittings. No forks, chains, straps, hooks, etc., shall be placed inside the pipe and fittings for lifting, positioning, or laying.

b. Exterior Coating

Bituminous outside coating shall be in accordance with ANSI/AWWA C151/A 21.51 for pipe and ANSI/AWWA C110/A 21.10 for fittings.

5. Fittings and gaskets for mechanical and push-on joint ductile and cast iron pipe shall conform to the latest revisions of ANSI/AWWA C110/A 21.10 for

mechanical and push-on joint fittings, ANSI/AWWA C111/A 21.11 for gaskets, and ANSI/AWWA C153/A 21.53 for mechanical and push-on joint compact fittings. Mechanical and push-on joint fittings shall have pressure class rating of 250 psi for sizes 20 inches and smaller and 200 psi for sizes larger than 20 inches.

6. All ductile and cast iron fittings shall be ductile iron grade 80-60-03 in accordance with ASTM A339-55.
7. Flanged ductile iron pipe shall conform to the latest revisions of ANSI/AWWA C115/A 21.15. Bolt pattern of flange shall be in accordance with ANSI/AWWA C115/A 21.15 (which is equivalent to ASME/ANSI B16.1, Class 125 flange bolt pattern). Pipe shall have pressure class 250 rating. Gaskets shall be synthetic rubber ring gaskets with a thickness of 1/8 inch. Nuts and bolts shall be in accordance with ASME/ANSI B18.2.1, ASME/ANSI B18.2.2, ASME/ANSI B1.1, and ASTM A307.
8. Flanged fittings shall conform to the latest revisions of ANSI/AWWA C110/A 21.10 or ANSI/AWWA C153/A 21.53 (compact fittings). Gaskets shall be in accordance with ANSI/AWWA C111/A 21.11. Fittings shall have pressure class rating of 250 psi. Bolt pattern of flange shall be in accordance with ANSI/AWWA C115/A 21.15 (which is equivalent to ASME/ANSI B16.1, class 125 flange bolt pattern).
9. Restrained joint pipe and fittings shall be a boltless system equal to "Field-Lok" restraining gaskets or "TRFLEX Joint" as manufactured by U.S. Pipe & Foundry Company. All pipe inside of casing pipe shall have restraining gaskets.
10. Ball and socket restrained joint pipe and fittings shall be a boltless system equal to USIFLEX manufactured by U.S. Pipe & Foundry Company or FLEX-LOK manufactured by American Pipe Company. Pipe shall have a working pressure rating of 250 psi and have a maximum joint deflection of 15°. Nominal laying lengths shall be in range of 18 feet 6 inches to 20 feet 6 inches.
11. **Manufacturers**

Pipe shall be as manufactured by U.S. Pipe & Foundry Company, Clow, American Cast Iron Pipe Company, or equal.
12. **Marking**

Pipe or fitting shall have the ANSI/AWWA standard, pressure (or thickness) class, diameter, DI or ductile noted, manufacturer, and country and year where cast on the outside of the body.
13. No separate pay item has been established for fittings and no determination of the number of fittings required on the job has been made. The Contractor, during the bidding phase, shall determine the number of fittings required on the job and include the cost of fittings and installation in the unit price for pipe.

C. Polyvinyl Chloride (PVC) Pipe

1. Solid Wall PVC Pipe (SDR 35)
 - a. PVC pipe and fittings less than 15 inches in diameter shall conform to the requirements of ASTM Standard Specifications for Type PSM Polyvinyl Chloride (PVC) Sewer Pipe and Fittings, Designation D 3034. Pipe and fittings shall have a minimum cell classification of 12454B or 12454C as defined in ASTM D-1784. All pipe shall have a pipe diameter to wall thickness ratio (SDR) of a maximum of 35.
 - b. PVC pipe and fitting with diameters 18-inch through 27-inch shall conform to the requirements of ASTM D-17845 and ASTM F-679. Pipe and fittings shall have a minimum cell classification of 14545C. The minimum wall thickness shall conform to T-1 as specified in ASTM F-679.
 - c. Joints shall be push-on bell and spigot type using elastomeric ring gaskets conforming to ASTM D 3212 and F 477. The gaskets shall be securely fixed into place in the bells so that they cannot be dislodged during joint assembly. The gaskets shall be of a composition and texture which is resistant to common ingredients of sewage and industrial wastes, including oils and groundwater, and which will endure permanently under the conditions of the proposed use.
 - d. Pipe shall be furnished in lengths of not more than 13 feet. The centerline of each pipe section shall not deviate from a straight line drawn between the centers of the openings at the ends by more than 1/16 inch per foot of length.
 - e. PVC pipe shall not have a filler content greater than ten percent (10%) by weight relative to PVC resin in the compound.
 - f. PVC pipe shall be clearly marked at intervals of 5 feet or less with the manufacturer's name or trademark, nominal pipe size, PVC cell classification, the legend "Type PSM SDR 35 PVC Sewer Pipe" and the designation "ASTM D 3034", or "ASTM F-679". Fittings shall be clearly marked with the manufacturer's name or trademark, nominal size, the material designation "PVC", "PSM" and the designation "ASTM D 3034", or "ASTM F-679".
 - g. PVC pipe shall have minimum pipe stiffness of 46 psi for each diameter when measured at 5 percent vertical ring deflection and tested in accordance with ASTM D 2412.
 - h. Five (5) copies of directions for handling and installing the pipe shall be furnished to the Contractor by the manufacturer at the first delivery of pipe to the job. PVC pipe installation shall conform to ASTM D-2321 latest revision.
 - i. Pipe shall be as manufactured by H & W Pipe Company, or equal.

D. Reinforced Concrete Pipe

1. All reinforced concrete pipe shall conform to the requirements of ASTM C76, latest edition. Class shall be as shown on the Drawings.
2. Joints shall be bell and spigot type using rubber Forsheda 138 or Forsheda 103 gaskets (or approved equal) and shall conform to ASTM C443.
3. The pipe shall be furnished in standard lengths of 8 feet to 16 feet.
4. The pipe shall be permanently marked showing the nominal inside diameter, manufacture date, ASTM C76 class, and manufacturer's name. These markings for 30-inch diameter and larger shall be inscribed on the pipe exterior and stenciled on the interior with paint or permanent ink.
5. There shall be no lift holes.
6. Pipe shall be as manufactured by Independent Concrete Pipe Company or approved equal.
7. Pipe Coatings

a. Interior Lining

(1) Description

All concrete pipe and fittings shall have a high build protective lining on the interior. All surface areas must be smooth without voids and projections, i.e. casting or manufacturing imperfections. Any patching of the interior of the concrete pipe shall be satisfactorily repaired by the pipe manufacturer by using a two component epoxy grout. No patching compounds containing a latex or acrylic base, or curing compounds shall be used on the interior surfaces of the concrete pipe to be lined. All rough and sharp edges on bells and spigots shall be rounded smooth with at least 1/8-inch radius.

(2) Lining Material

The material must be a high build multi-component amine cured novalac epoxy polymeric lining. The standard of quality is Inner-Liner by Vulcan Painters, Birmingham, Alabama. Equal products considered are Protecto Pipe Lining 1011 and PERMITE 9043 Type 2 polyamide epoxy. Any other alternates must be accompanied by the following:

- (a) The permeability rating equal to the specified material when tested according to Method A of ASTM E-96-66, Procedure A, with a test duration of 42 days as reported by an independent laboratory.

- (b) A statement from the Manufacturer of the submitted material attesting to the fact that at least 20% of the volume of the lining contains ceramic quartz pigment or similar inert material that will not be affected by the sewer liquids and gas.
 - (c) A laboratory report containing test data for immersion in acids, bases, and deionized water equal to the performance of the specified material using ASTM D-714-56 (1974) for the rating method.
 - (d) A statement concerning recoatability and repair to the lining.
- (3) Concrete Pipe and Manholes
- (a) Surface Preparation

All centrifugally cast concrete pipe shall have the interior fines, which include the gray layer of loosely-bound laitance, washed out at the time of manufacture. The intent is to expose tightly-bound concrete so that the lining will have a sound substrate for adhesion. After the pipe has cured the equivalent of seven (7) days at 77°F, the interior of the pipe exposed to liquids and gases shall be blasted and cleaned to remove all laitance, form oils, or other loose material. All none-water soluble grease or oils shall be removed by the pipe manufacturer before surface preparation by steam cleaning.

(b) Lining

After cleaning, the lining material shall be applied at 40 mils for the complete system using a centrifugal lance applicator. No lining shall take place over grease, oil, etc., that would be detrimental to the adhesion of the compound to the substrate. The compound shall not be applied when the substrate temperature is below 40°F or in adverse atmosphere conditions which will cause detrimental blistering, pinholing, or porosity of the film. In no case shall the lining be applied when the concrete surface is above 14% moisture content.

(c) Coating of Gasket and Spigot Ends

Due to tolerances, the joint areas must be coated with 6 mils, 10 mils maximum, Inner-Liner joint compound. It is the pipe manufacturer's responsibility to ensure that these tolerances are acceptable. This coating shall be hand-applied by brush to ensure a continuous protective

barrier. Care should be taken that the coating is smooth without excess buildup in the gasket area of the bell or on the gasket groove on the spigot end. All materials for the gasket groove and spigot end shall be applied after the application of the lining.

(4) Inspection and Certification

(a) Inspection

(a1) All concrete pipe and manholes shall be checked for thickness using a magnetic film thickness gauge on metal coupons attached to 5% of the pipe lined. **Note:** All dry film thickness shall be measured by application Specification No. 2 (SSPC-PA2 November 1, 1982).

(a2) The barrel of all pipe and fittings shall be pinhole-detected with a non-destructive 2,500-volt pinhole test. This test shall take place as soon as the lining is cured to prevent damage or contamination on the lining surfaces.

(a3) Each pipe joint and fitting shall be marked with the date of application of the lining system and with its numerical sequence of application on that date.

(a4) All pipe and fittings shall be inspected visually before and after installation, if possible, to ensure that any defect or damage to the pipe or lining is repaired prior to placing in service.

(b) Certification

The pipe or fitting manufacturer must supply a certificate attesting to the fact that the applicator met the requirements of this specification, and that the material used was as specified, and that the material was applied as required by the specification.

(5) Field Touch-Up

(a) Surface Preparation

(a1) The damaged or abraded area should be brushed vigorously with a wire brush or sanded with coarse sandpaper to remove all loose material. After the surface has been cleaned, care should be

taken to remove all dust from the cleaning operation. This can be accomplished by blowing-off with compressed air or by brushing with a dry brush.

(a2) Inner-Liner Joint Compound shall be used for touchup or repair and shall be mixed thoroughly in strict accordance with manufacturer's recommendations. After the material has been thoroughly mixed, apply to the prepared surface by either brush, roller, or airless spray. The material will be applied in one or two coats, as directed by the Engineer, depending on the size of the damaged area and whether it goes to the substrate or not. All touch-up shall be applied using the guidelines established for temperature and moisture content in paragraph for "Lining".

b. Exterior Coating

All reinforced concrete pipe shall be water-proofed on the exterior with asphalt coating. (Steel cylinder concrete pipe does not have to be water-proofed.)

PART 3 - EXECUTION

3.01 PIPE LAYING

- A. All pipe shall be laid with ends abutting and true to the lines and grades indicated on the Drawings. The pipe shall be laid straight between changes in alignment and at uniform grade between changes in grade. Pipe shall be fitted and matched so that when laid in the trench, it will provide a smooth and uniform invert. Supporting of pipe shall be as set out in Section 02225 and in no case shall the supporting of pipe on blocks be permitted.
- B. Before each piece of pipe is lowered into the trench, it shall be thoroughly swabbed out to insure its being clean. Any piece of pipe or fitting which is known to be defective shall not be laid or placed in the lines. If any defective pipe or fitting shall be discovered after the pipe is laid, it shall be removed and replaced with a satisfactory pipe or fitting without additional charge. In case a length of pipe is cut to fit in a line, it shall be so cut as to leave a smooth end at right angles to the longitudinal axis of the pipe and beveled to match the factory bevel for insertion into gasketed joints. Bevel can be made with hand or power tools.
- C. The interior of the pipe, as work progresses, shall be cleaned of dirt, jointing materials, and superfluous materials of every description. When laying of pipe is stopped for any reason, the exposed end of such pipe shall be closed with a plywood plug fitted into the pipe bell so as to exclude earth or other material and precautions taken to prevent flotation of pipe by runoff into trench.

- D. All pipe shall be laid starting at the lowest point and installed so that the spigot ends point in the direction of flow.

3.02 JOINTING

All joint surfaces shall be cleaned immediately before jointing the pipe. The bell or groove shall be lubricated in accordance with the manufacturer's recommendation. Each pipe unit shall then be carefully pushed into place without damage to pipe or gasket. All pipe shall be provided with home marks to insure proper gasket seating. Details of gasket installation and joint assembly shall follow the direction of the manufacturer's of the joint material and of the pipe. The resulting joints shall be watertight and flexible. **No solvent cement joints shall be allowed.**

3.03 UTILITY CROSSING CONCRETE ENCASEMENT

- A. At locations shown on the Drawings, required by the Specifications, or as directed by the Engineer, concrete encasement shall be used when the clearance between the proposed sanitary sewer pipe and any existing utility pipe is 18 inches or less. Utility pipe includes underground water, gas, telephone and electrical conduit, storm sewers, and any other pipe as determined by the Engineer.
- B. There are two cases of utility crossing encasement. Case I is applicable when the proposed sanitary sewer line is **below** the existing utility line. Case II is applicable when the proposed sanitary sewer line is laid **above** the utility line. In either case, the concrete shall extend to at least the spring line of each pipe involved.
- C. Concrete shall be Class B (3000 psi) and shall be mixed sufficiently wet to permit it to flow between the pipes to form a continuous bridge. In tamping the concrete, care shall be taken not to disturb the grade or line of either pipe or damage the joints.
- D. Concrete for the Work is not a separate pay item and will be considered incidental to utility pipe installation.

3.04 TESTING OF GRAVITY SEWER LINES

- A. After the gravity piping system has been brought to completion, and prior to final inspection, the Contractor shall rod out the entire system by pushing through each individual line in the system, from manhole to manhole, appropriate tools for the removal from the line of any and all dirt, debris, and trash. If necessary during the process of rodding the system, water shall be turned into the system in such quantities to carry off the dirt, debris, and trash.
- B. During the final inspection the Engineer will require all flexible sanitary sewer pipe to be mandrel deflection tested after installation.
 - 1. The mandrel (go/no-go) device shall be cylindrical in shape and constructed with nine (9) evenly spaced arms of prongs. The mandrel dimension shall be 95 percent of the flexible pipe's published ASTM average inside diameter. Allowances for pipe wall thickness tolerances of ovality (from shipment, heat, shipping loads, poor production, etc.) shall not be deducted from the ASTM average inside diameter, but shall be counted as part of the 5 percent allowance. The contact length of the

mandrel's arms shall equal or exceed the nominal diameter of the sewer to be inspected. Critical mandrel dimensions shall carry a tolerance ± 0.001 inch.

2. The mandrel inspection shall be conducted no earlier than 30 days after reaching final trench backfill grade provided, in the opinion of the Engineer, sufficient water densification or rainfall has occurred to thoroughly settle the soil throughout the entire trench depth. Short-term (tested 30 days after installation) deflection shall not exceed 5 percent of the pipe's average inside diameter. The mandrel shall be hand pulled by the contractor through all sewer lines. Any sections of the sewer not passing the mandrel test shall be uncovered and the Contractor shall replace and recompact the embedment backfill material to the satisfaction of the Engineer. These repaired sections shall be retested with the go/no-go mandrel until passing.
 3. The Engineer shall be responsible for approving the mandrel. Proving rings may be used to assist in this. Drawings of the mandrel with complete dimensioning shall be furnished by the Contractor to the Engineer for each diameter and type of flexible pipe.
- C. The pipe line shall be made as nearly watertight as practicable, and leakage tests and measurements shall be made. All apparatus and equipment required for testing shall be furnished by the Contractor and the cost shall be included in the unit price bid for pipe and manholes.
1. The Engineer may require the Contractor to smoke test the first section (manhole to manhole) of each size of pipe and type of joint prior to backfilling, to establish and check laying and jointing procedures. The test shall consist of smoke blown into closed-off sections of sewer under pressure and observing any smoke coming from the pipe line indicating the presence of leaks. Other supplementary smoke tests prior to backfilling may be performed by the Contractor at his option; however, any such tests shall not supplant the final tests of the completed work unless such final tests are waived by the Engineer.
 2. Where the groundwater level is more than 1 foot above the top of the pipe at its upper end, the Contractor shall conduct either infiltration tests or low pressure air tests on the completed pipeline.
 3. Where the groundwater level is less than 1 foot above the top of the pipe at its upper end, the Contractor shall conduct either exfiltration tests or low pressure air tests on the completed pipeline.
- D. Low-pressure air tests shall be performed on all gravity sanitary sewers to verify watertightness of pipe joints and connections. The Contractor shall perform testing on each manhole-to-manhole section of sewer line after placement of backfill.

Testing of Polyvinyl Chloride (PVC) and Ductile Iron (DI) pipe sewer lines shall be performed in accordance with the current editions of ASTM F1417, "Standard Test Method for Installation Acceptance of Plastic Gravity Sewer Lines Using Low-Pressure Air," and UNI-B-6, "Recommended Practice for Low-Pressure Air Testing of Installed Sewer Pipe," respectively. Testing of reinforced concrete pipe sewer lines shall be performed in accordance with the current edition of ASTM C 924, "Standard Practice for Testing Concrete Pipe Sewer Lines by Low-Pressure Air Test Method."

All testing equipment shall be inspected by the Engineer to ensure that equipment is functioning properly.

The rate of air loss in the section under test shall be determined by the time-pressure drop method. The time required in minutes for the pressure in the section under test to decrease from 3.5 to 2.5 psig shall be not less than that indicated in the referenced standards.

Immediately following the low-pressure air test, the Contractor shall notify the Engineer of the test results. A Low-Pressure Air Test Report shall be completed by the Contractor during testing. The report shall be completed according to the procedures outlined in LFUCG's Construction Inspection Manual, current edition. A copy of the completed Low-Pressure Air Test Report shall be provided to the Engineer and LFUCG-Division of Water Quality for each test.

Pipes failing the pressure test will not be accepted and shall be repaired or replaced until a successful test is achieved.

When conducting a low-pressure air test, the Contractor shall securely install and brace all plugs prior to pressurizing the pipe. Personnel shall not be permitted to enter manholes when the sewer pipe is pressurized.

- E. Infiltration tests (for concrete pipe only) shall be made after underdrains, if present, have been plugged and other groundwater drainage has been stopped such that the groundwater is permitted to return to its normal level insofar as practicable.
 - 1. Upon completion of a section of the pipeline, the line shall be dewatered and a satisfactory test conducted to measure infiltration for at least 24 hours. The amount of infiltration, including manholes, tees and connections, shall not exceed 200 gallons per nominal inch diameter per mile of sewer per 24 hours.

- F. Exfiltration tests (for concrete pipe only) which subject the pipeline to an internal pressure, shall be made by plugging the pipe at the lower end and then filling the line and manholes with clean water to a height of 2 feet above the top of the sewer at its upper end. Where conditions between manholes may result in test pressures which would cause leakage at the plugs or stoppers in branches, provisions shall be made by suitable ties, braces and wedges to secure the plugs against leakage resulting from the test pressure.
 - 1. The rate of leakage from the sewers shall be determined by measuring the amount of water required to maintain the level 2 feet above the top of the pipe.
 - 2. Leakage from the sewers under test shall not exceed the requirements for leakage into sewers as hereinbefore specified.

- G. The Contractor shall furnish suitable test plugs, water pumps, and appurtenances, and all labor required to properly conduct the tests. Suitable bulkheads shall be installed, as required, to permit the test of the sewer. The Contractor shall construct weirs or other means of measurements as may be necessary.

- H. Should the sections under test fail to meet the requirements, the Contractor shall do all work of locating and repairing the leaks and retesting as the Engineer may require without additional compensation.
- I. If in the judgment of the Engineer, it is impracticable to follow the foregoing procedures for any reason, modifications in the procedures shall be made as required and as acceptable to the Engineer, but in any event, the Contractor shall be responsible for the ultimate tightness of the line within the above test requirements.

- END OF SECTION -

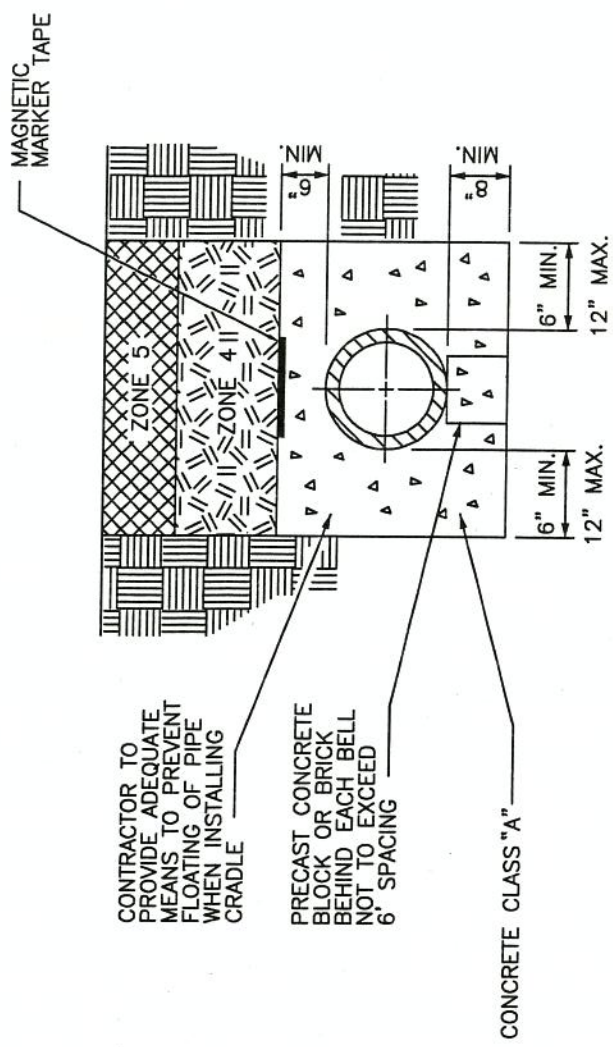

STANDARD CONCRETE ENCASEMENT
(NOTE: AS REQUIRED BY DESIGN)

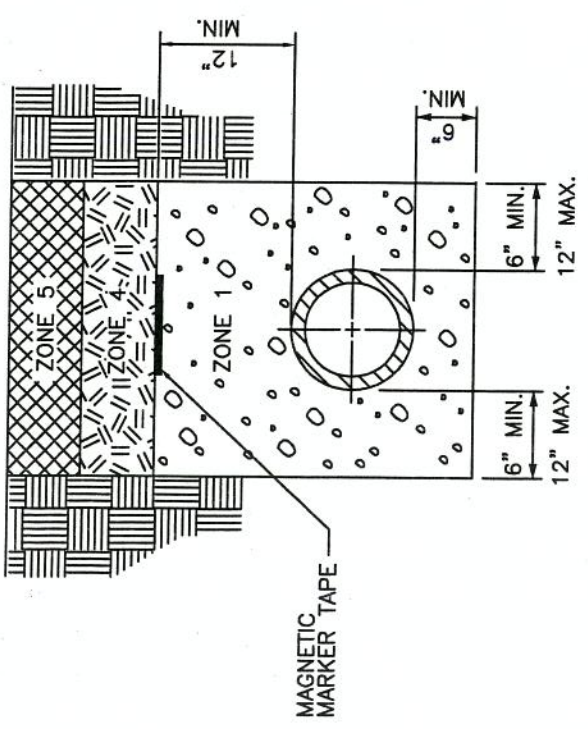

PIPE LAID IN ROCK
OR SOIL TRENCH

PIPE BACKFILL DESCRIPTIONS	
ZONE 1	NO. 9 STONE
ZONE 2	NO. 9 OR NO. 57 STONE
ZONE 3	COMPACTED DGA
ZONE 4	CONSOLIDATED SOIL, (NO ROCK GREATER THAN 6" DIAMETER), NO. 9, OR NO. 57 STONE
ZONE 5	12" MAX. TOPSOIL, NO ROCK ALLOWED

NOTES:

1. COVER, UP TO AND INCLUDING ZONE 4 SHALL BE ESTABLISHED BEFORE TRENCH EXCAVATION.
2. ALL SANITARY SEWER LINES CONSTRUCTED FROM NON-METALLIC MATERIALS SHALL HAVE MAGNETIC MARKER TAPE INSTALLED IN THE TRENCH ABOVE THE SANITARY SEWER LINE.
3. MAGNETIC MARKER TAPE FOR SANITARY SEWER ONLY.

NO.	DATE	REVISION DESCRIPTION	BY

DIVISION OF ENGINEERING

TRENCHING, LAYING
BACKFILLING AND BEDDING
OUTSIDE R/W LIMITS

STANDARD DRAWING NO. 200
APPROVAL BY: *[Signature]* DATE: 5/1/05
DESIGNED BY: *[Signature]* DATE: *[Blank]*
CHECKED BY: *[Signature]* DATE: *[Blank]*
COMMISSIONER

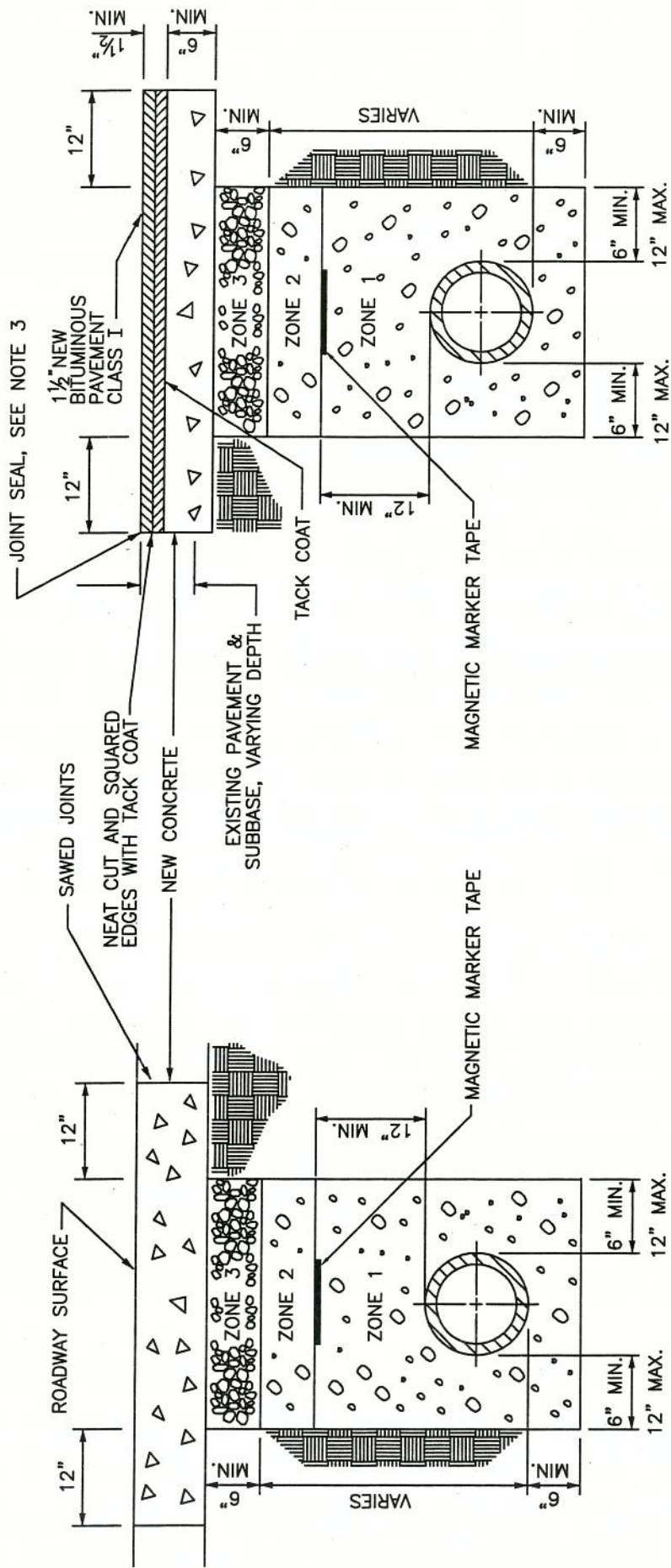

CONCRETE PAVEMENT

BITUMINOUS PAVEMENT

NOTES:

1. REPLACE CONCRETE PAVEMENT WITH NEW CONCRETE PAVEMENT 6" MINIMUM OR EXISTING THICKNESS, WHICHEVER IS GREATER.
2. JOINT SEAL PERIMETER OF CUT PAVEMENT WITH FLEXMASTER POURABLE CRACK SEALANT 1109 OR APPROVED EQUAL.
3. MAGNETIC MARKER TAPE FOR SANITARY SEWER ONLY.

PIPE BACKFILL DESCRIPTIONS	
ZONE 1	NO. 9 STONE
ZONE 2	NO. 9 OR NO. 57 STONE
ZONE 3	COMPACTED DGA
ZONE 4	CONSOLIDATED SOIL (NO ROCK GREATER THAN 6" DIAMETER), NO. 9, OR NO. 57 STONE
ZONE 5	12" MAX. TOPSOIL NO ROCK ALLOWED

NO.	DATE	REVISION DESCRIPTION	BY

DIVISION OF ENGINEERING

TRENCHING, LAYING BACKFILLING AND BEDDING UNDER STREET PAVEMENT

STANDARD DRAWING NO. 201
APPROVED: [Signature]
URBAN COUNTY COMMISSIONER

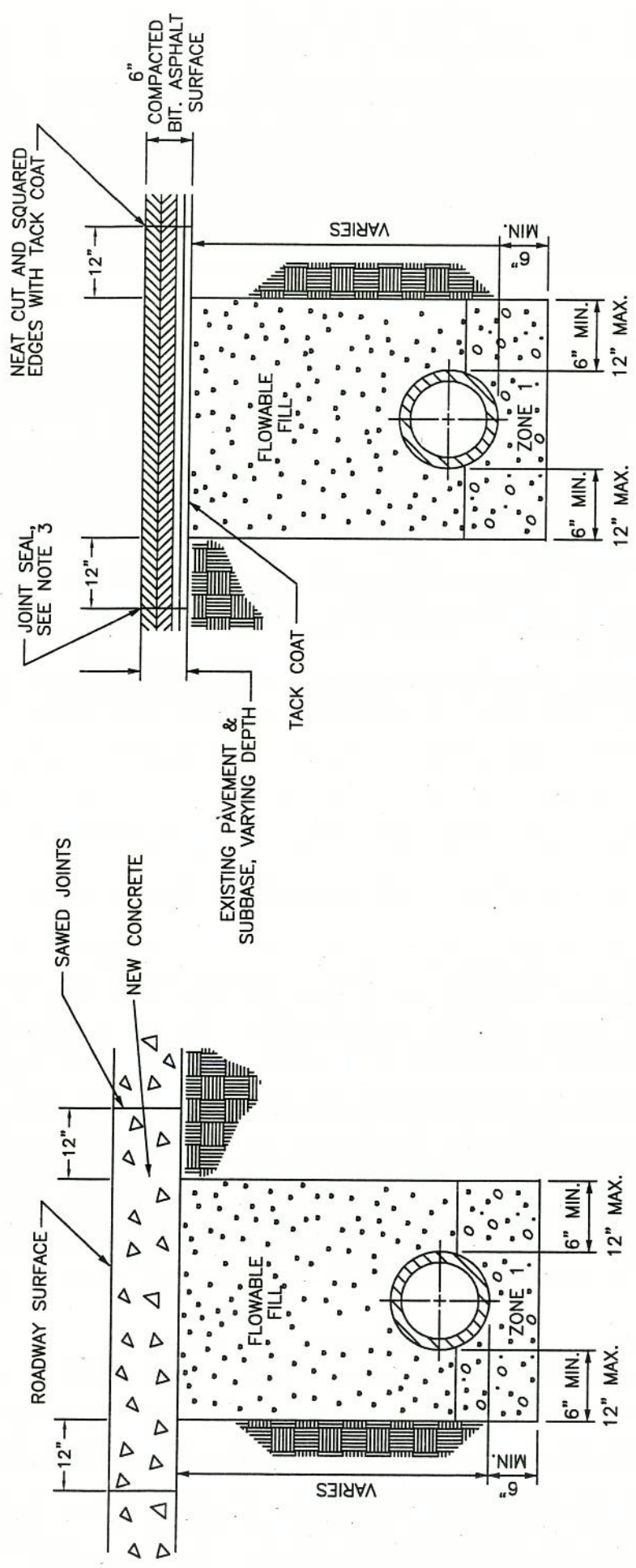

CONCRETE PAVEMENT

BITUMINOUS PAVEMENT

PIPE BACKFILL DESCRIPTIONS	
ZONE 1	NO. 9 STONE
ZONE 2	NO. 9 OR NO. 57 STONE
ZONE 3	COMPACTED DGA
ZONE 4	CONSOLIDATED SOIL, (NO ROCK GREATER THAN 6" DIAMETER), NO. 9, OR NO. 57 STONE
ZONE 5	12" MAX. TOPSOIL, NO ROCK ALLOWED

- NOTES:**
- PER KYTC SPECIFICATION 601.03.03 FROM STANDARD SPECIFICATIONS FOR ROAD AND BRIDGE CONSTRUCTION EDITION 2004, OR MOST RECENT.
 - REPLACE CONCRETE PAVEMENT WITH NEW CONCRETE PAVEMENT, 6" MINIMUM OR EXISTING THICKNESS, WHICHEVER IS GREATER.
 - JOINT SEAL PERIMETER OF CUT PAVEMENT WITH FLEXMASTER POURABLE CRACK SEALANT 1109 OR APPROVED EQUAL.

NO.	DATE	REVISION DESCRIPTION	BY

DIVISION OF ENGINEERING

TRENCHING, LAYING, BACKFILLING, AND BEDDING UNDER STREET PAVEMENT USING FLOWABLE FILL

STANDARD DRAWING NO. 201-22
APPROVAL DATE 5/1/04
URBAN COUNTY ENGINEER
COMMISSIONER